

# Vacuum Equipment



Vacuum Module: **ZX** ..... P. 13-2-4

Vacuum Module: **ZR** ..... P. 13-3-4

Vacuum Ejector: **ZM** ..... P. 13-4-2

Vacuum Ejector with  
Solid State Timer: **ZMA** ..... P. 13-4-23

Vacuum Ejector: **ZH** ..... P. 13-5-2

In-line Vacuum Ejector: **ZU** ... P. 13-6-3

Vacuum Ejector: **ZL** ..... P. 13-7-4

Ejector Valve Unit: **ZYY/ZYX** ... P. 13-8-4

Compact Vacuum Ejector: **ZQ** ... P. 13-9-2

Air Suction Filter: **ZFA** ..... P. 13-10-1

Air Suction Filter  
with One-touch Fittings: **ZFB** ... P. 13-10-4

Air Suction Filter In-line Type  
with One-touch Fittings: **ZFC** ... P. 13-10-7

Vacuum Pad: **ZPT** ..... P. 13-11-2

Large/Heavy Duty Type  
(ø40 to ø125): **ZPT/ZPX** ..... P. 13-11-72

Large Size Bellows Type  
(ø40 to ø125): **ZPT/ZPX** ..... P. 13-11-86

Ball Joint Type  
(ø10 to ø50): **ZPT/ZPR** ..... P. 13-11-104

Free Mount Cylinder  
for Vacuum: **ZCUK** ..... P. 13-12-2

Drain Separator  
for Vacuum: **AMJ** ..... P. 13-13-3

Vacuum System Peripherals: ... P. 13-14-2  
Related Products: ..... P. 13-14-13  
Manifold Specification Sheet ... P. 13-14-17

Precautions ..... P. 13-1-5  
Technical Data ..... P. 13-1-10

ZX

ZR

ZM

ZH

ZU

ZL

ZY

ZQ

ZF

ZP

ZCU





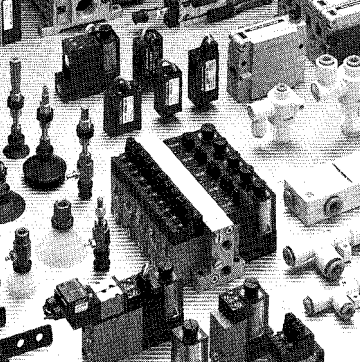





AMJ

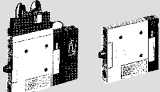

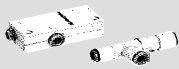

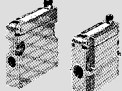

Misc.



# Vacuum Equipment

Vacuum Modular/Vacuum Ejector/Air Suction Filter  
 Air Suction Filter with One-touch Fitting/Vacuum Switch  
 Vacuum Pad/Free Mount Cylinder for Vacuum

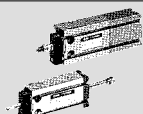
Technical Data	<ul style="list-style-type: none"> <li>• Adsorption transfer system by ejector</li> <li>• Adsorption transfer system by vacuum pump</li> <li>• Vacuum equipment model selection/pads, ejectors, and vacuum switching valves</li> </ul>		Page	
<b>Vacuum Module</b>	<i>Series ZX</i>	<ul style="list-style-type: none"> <li>• Optimal for electronic parts or small precision parts weighing up to 100 g</li> <li>• Supports the ejector system and the vacuum pump system</li> <li>• Modular design</li> <li>• Adaptable for manifold applications</li> </ul>		13-2-4
<b>Vacuum Module</b>	<i>Series ZR</i>	<ul style="list-style-type: none"> <li>• Necessary functions can be combined through modular design</li> <li>• Adaptable for manifold applications</li> <li>• Functions such as a digital vacuum switch or a solenoid valve can be selected</li> <li>• Supports the ejector system and the vacuum pump system</li> <li>• Double solenoids provide a self-holding function</li> </ul>		13-3-4
<b>Vacuum Ejector</b>	<i>Series ZM</i>	<ul style="list-style-type: none"> <li>• Valve and switch are unitized</li> <li>• Adaptable for manifold applications</li> <li>• Maximum suction flow rate increased 40%</li> <li>• Max. vacuum pressure -84 kPa {-630 mmHg}</li> </ul>		13-4-2
<b>Vacuum Ejector with Solid State Timer</b>	<i>Series ZMA</i>	<ul style="list-style-type: none"> <li>• Incorporates solid state timer function for release valve control (timer setting with PLC is unnecessary)</li> <li>• Allows sharing of switch/valve power supply, and single line for suction signal (valve wiring is unnecessary)</li> <li>• Timer can be easily adjusted without programming</li> </ul>		13-4-23
<b>Vacuum Ejector</b>	<i>Series ZH</i>	<ul style="list-style-type: none"> <li>• Nozzle diameter: <math>\phi 0.5</math>, <math>\phi 0.7</math>, <math>\phi 1.0</math>, <math>\phi 1.3</math>, <math>\phi 1.5</math>, <math>\phi 1.8</math>, <math>\phi 2.0</math></li> <li>• Composite resin nozzle and body</li> <li>• Available in 2 types: box type and direct piping type</li> </ul>		13-5-2
<b>In-line Vacuum Ejector</b>	<i>Series ZU</i>	<ul style="list-style-type: none"> <li>• Nozzle diameter: <math>\phi 0.5</math>, <math>\phi 0.7</math></li> <li>• Vacuum port and supply port are located collinearly to facilitate piping</li> <li>• Built-in One-touch fitting (Copper free)</li> </ul>		13-6-3
<b>Vacuum Ejector</b>	<i>Series ZL</i>	<ul style="list-style-type: none"> <li>• Suction flow rate increased by a 3 stage diffuser construction</li> <li>• Functions such as a digital vacuum switch or a vacuum pressure gauge can be selected</li> </ul>		13-7-4
<b>Ejector Valve</b>	<i>Series ZYY/ZYX</i>	<ul style="list-style-type: none"> <li>• Ejector valve unit suitable for vacuum adsorption systems</li> <li>• A combination of solenoid valve for cylinder drive, etc + vacuum ejector</li> </ul>		13-8-4
<b>Air Suction Filter</b>	<i>Series ZFA</i>	<ul style="list-style-type: none"> <li>• Prevents problems related to vacuum circuits or airborne contaminants</li> <li>• Provides a large filter element surface</li> </ul>		13-10-1
<b>Air Suction Filter</b>	<i>Series ZFB</i>	<ul style="list-style-type: none"> <li>• Prevents problems related to vacuum circuits or airborne contaminants</li> <li>• Piping tube can be connected and disconnected with one touch</li> </ul>		13-10-4
<b>Air Suction Filter In-line Type with One-touch Fittings</b>	<i>Series ZFC</i>	<ul style="list-style-type: none"> <li>• IN/OUT straight piping</li> <li>• One-touch fittings for easy installation and removal</li> <li>• Lightweight molded resin parts</li> <li>• Cartridge type element replacement</li> </ul>		13-10-7

<b>Vacuum Pad</b>	<b>Series ZP</b>	<ul style="list-style-type: none"> <li>• A variety of models accommodate a wide range of applications</li> <li>• Pad type: Flat, Flat with ribs, Deep, Bellows</li> <li>• Pad diameter: ø2 to ø125, Made to Order = ø150 to ø250</li> </ul>		13-11-2				
<b>Vacuum Pad Large/Heavy Duty Type</b>	<b>Series ZPT/ZPX</b>	<ul style="list-style-type: none"> <li>• Ideal for heavy weight material or objects with a large surface area Example: CRT, Car body</li> <li>• Pad diameter: ø40, ø50, ø63, ø80, ø100, ø125</li> </ul>		13-11-72				
<b>Vacuum Pad Large Size Bellows Type</b>	<b>Series ZPT/ZPX</b>	<ul style="list-style-type: none"> <li>• Ideal for loads with a curved surface, heavy weight loads and loads with large surface area</li> <li>• Pad diameter: ø40, ø50, ø63, ø80, ø100, ø125</li> </ul>		13-11-86				
<b>Vacuum Pad Ball Joint Type</b>	<b>Series ZPT/ZPR</b>	<ul style="list-style-type: none"> <li>• Ball joint type ideal for adsorption on slanted work surface</li> <li>• Pad diameter: ø10, ø13, ø16, ø20, ø25, ø32, ø40, ø50</li> </ul>		13-11-104				
<b>Free Mount Cylinder for Vacuum</b>	<b>Series ZCUK</b>	<ul style="list-style-type: none"> <li>• In the rectangular, compact cylinder Series CU with a high level of mounting precision, a vacuum passage is provided to facilitate the mounting of a vacuum pad and to save space.</li> <li>• Standard vacuum pads (ø2 to ø50) can be mounted</li> </ul>		13-12-2				
<b>Drain Separator for Vacuum</b>	<b>Series AMJ</b>	<ul style="list-style-type: none"> <li>• Remove water droplets from air by simply installing in vacuum equipment connection line. Effective for removing water droplets from the air sucked into vacuum pumps and ejectors, etc.</li> </ul>		13-13-3				
<b>Vacuum Switch</b>	<b>Series ZS</b>	Refer to Best Pneumatics Vol.16 for more details on vacuum switches.	<table border="1"> <tr> <td><b>Vacuum System Peripherals: Related Products:</b></td> <td>.....13-14-2</td> </tr> <tr> <td><b>Manifold Specification Sheet</b></td> <td>.....13-14-17</td> </tr> </table>	<b>Vacuum System Peripherals: Related Products:</b>	.....13-14-2	<b>Manifold Specification Sheet</b>	.....13-14-17	
<b>Vacuum System Peripherals: Related Products:</b>	.....13-14-2							
<b>Manifold Specification Sheet</b>	.....13-14-17							

# Vacuum Equipment Precautions



Be sure to read before handling. Refer to pages 13-15-3 to 13-15-4 for Safety Instructions and Common Precautions on the products mentioned in this catalog, and refer to main text for more detailed precautions of every series.

## Design & Selection

### ⚠ Warning

1. **Safe designs should be developed, which account for the possibility of accidents resulting from a drop in vacuum pressure due to power failure or trouble with the air supply, etc.**

If vacuum pressure drops and there is a loss of vacuum pad adsorption force, workpieces being carried may fall, causing human injury or damage to machinery. Safety measures should be implemented such as the installation of drop prevention guides.

2. **Follow vacuum specifications for vacuum switching valves and vacuum breakers.**

If valves are installed in vacuum piping which do not follow vacuum specifications, vacuum leakage will occur. Be certain to use vacuum specification valves.

3. **Select ejectors which have a suitable suction flow rate.**

<When there is a vacuum leak from the workpiece or the piping>  
If the ejector's suction flow rate is too low, this will cause poor adsorption.

<When piping is long or of large diameter>

The adsorption response time will increase due to the increased volume of the piping.

Select ejectors with a suitable suction flow rate by referring to their technical data.

4. **If the suction flow rate is too high, setting of vacuum switches will become difficult.**

In the case of adsorbing a small workpiece of only a few millimeters, if an ejector is selected which has a high suction flow rate, the pressure difference when adsorbing and releasing the workpiece is small, and sometimes setting of the vacuum switch becomes difficult. Therefore, an appropriate ejector should be selected.

5. **When two or more pads are piped to one ejector, if one pad releases its workpiece, the other pads will also release.**

When one pad is removed from its workpiece, there is a drop in vacuum pressure which causes the other pads to release their workpieces also.

6. **Use piping with an adequate effective sectional area.** Select piping for the vacuum side which has an adequate effective sectional area, so that the ejector's maximum suction flow rate can be accommodated by the piping.

Also, make sure that there are no unnecessary restrictions or leaks, etc. along the course of the piping.

The piping on the air supply side must be designed so that it corresponds to each ejector's air consumption. The effective sectional area of tubing, fittings and valves, etc., should be sufficiently large, and the pressure drop reaching the ejector should be kept to a minimum.

Furthermore, design of the air supply should be performed while taking into consideration the ejector's maximum air consumption and the air consumption of other pneumatic circuits.

### ⚠ Caution

1. **For information on related items, such as directional control equipment and drive equipment, refer to the caution sections in each respective catalog.**
2. **If there is vibration, the needle for flow adjustment of valve may be loosened. To prevent from loosening, a lock nut type is available. Confirm the part number.**

## Mounting

### ⚠ Warning

1. **Do not obstruct the exhaust port of the ejector.**

If the exhaust port is obstructed when mounted, a vacuum will not be generated.

## Piping

### ⚠ Caution

1. **Avoid disorganized piping.**

Piping which is direct and of the shortest possible length should be used for both the vacuum and supply sides, and disorganized piping should be avoided. Unnecessary length increases the piping volume, and thus increases the response time.

2. **Use piping with a large effective sectional area on the exhaust side of the ejector.**

If the exhaust piping is restrictive, there will be a decline in the ejector's performance.

3. **Make sure that there are no crushed areas in the piping due to damage or bending.**

## Operating Environment

### ⚠ Warning

1. **Do not operate in atmospheres of corrosive gases, chemicals, sea water, water or steam.**
2. **Do not operate in explosive areas.**
3. **Do not operate in locations where vibration or impact occurs. Confirm the specifications for each series.**
4. **In locations which receive direct sunlight, provide a protective cover, etc.**
5. **In locations near heat sources, protect against radiated heat.**
6. **In locations where there is contact with spatter from water, oil or solder, etc., implement suitable protective measures.**
7. **In cases where the vacuum unit is surrounded by other equipment, etc., or the unit is energized for an extended time, implement measures to exhaust excess heat, so that temperatures remain within the range of the vacuum unit's specifications.**

## Maintenance

### ⚠ Warning

1. **Clean suction filters and silencers on a regular basis. (Refer to specifications.)**

The performance of ejectors will deteriorate due to clogging in filters and silencers. Large flow filters should be used, especially in dusty locations.

# Adsorption Transfer System by Ejector

## Ejector Module System

Equipment (ejector supply valve, vacuum release valve, throttle valve, vacuum pressure switch, and filter) that is needed for the ejector adsorption transfer system has been integrated to achieve efficient assembly work and a compact design.

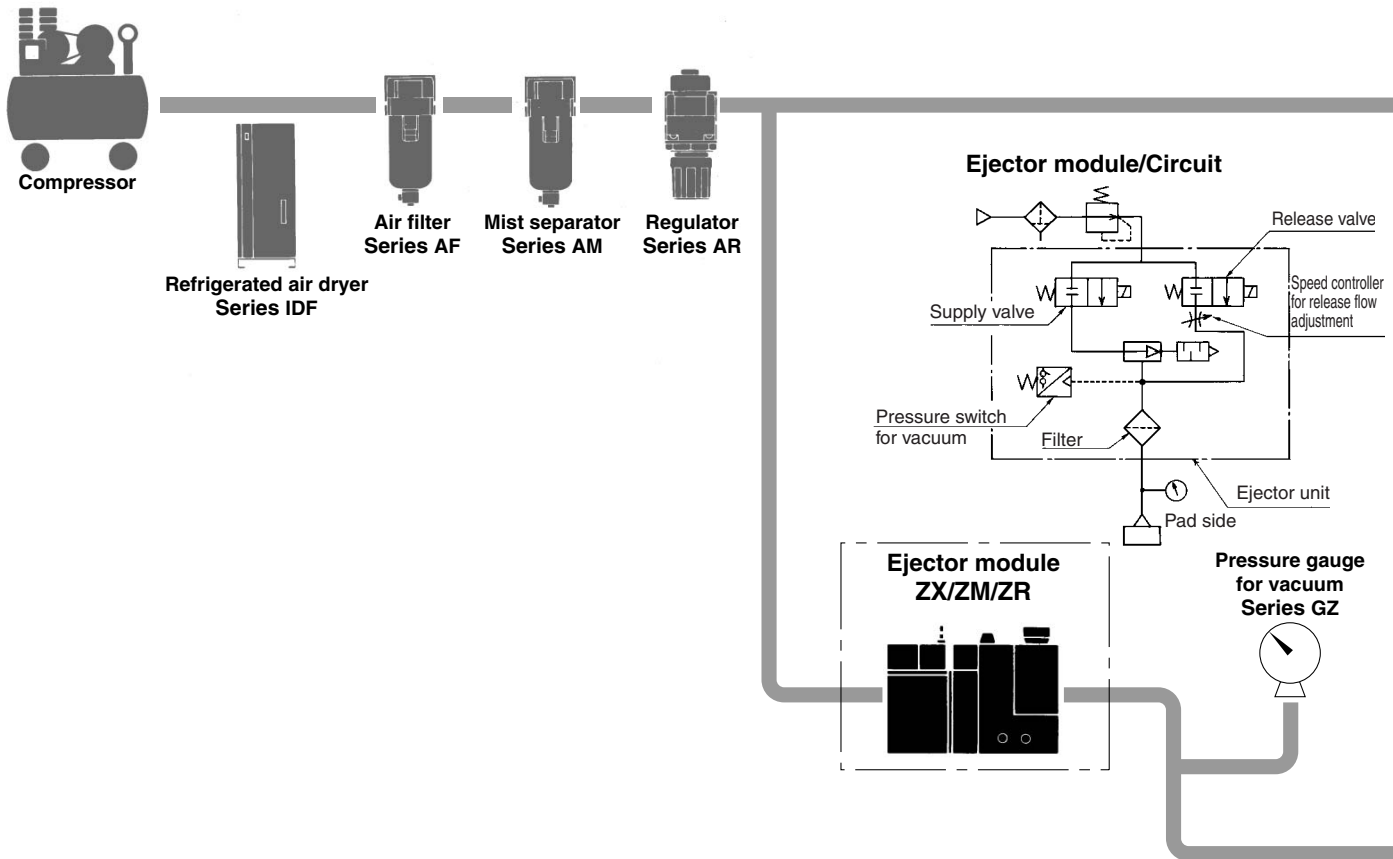

### Ejector System Component Equipment

Ejector System Component Equipment							
Series	Features	Ejector nozzle dia. (mm)	Component equipment			Page	
			Supply valve	Release valve	Vacuum switch	Filter	
<b>Vacuum module</b> <i>Series ZX</i>	Can also accommodate a vacuum pump for the adsorption conveyance of small items such as electronic parts.	ø0.5 to ø1.0	●	●	●	●	13-2-4
<b>Vacuum ejector</b> <i>Series ZM</i>	Using an ejector with a 2-stage nozzle, the ejector system can be used most efficiently.	ø0.5 to ø1.3	●	●	●	●	13-4-2
<b>Large vacuum module</b> <i>Series ZR</i>	<ul style="list-style-type: none"> <li>Double solenoids provide a self-holding function.</li> <li>Necessary functions can be combined through modular design.</li> <li>Can also accommodate a vacuum pump.</li> </ul>	ø1.0 to ø2.0	●	●	●	●	13-3-4

Single Unit Equipment		
Series	Features	Page
<b>Vacuum ejector</b> <i>Series ZH</i>	Nozzle diameter ø0.5 to 1.3 mm Can be connected with the combination of a one-touch and a screw-in connection.	13-5-2
<b>Multi-stage ejector</b> <i>Series ZL</i>	<ul style="list-style-type: none"> <li>Suction flow rate increased by a 3-stage diffuser construction.</li> <li>Functions such as a digital vacuum switch or a vacuum pressure gauge can be selected.</li> </ul>	13-7-4
<b>Ejector valve</b> <i>Series ZYYZYX</i>	Solenoid valve for operating cylinder, etc. + vacuum ejector	13-8-4
<b>Air suction filter</b> <i>Series ZFA</i>	Prevents problems related to vacuum circuits or airborne contaminants. Maximum flow rate 200 l/min (ANR). The collected dust does not remain in the case.	13-10-1
<b>Air suction filter</b> <i>Series ZFB</i>	<ul style="list-style-type: none"> <li>Prevents problems related to vacuum circuits or airborne contaminants.</li> <li>Maximum flow rate l/min (ANR) (metric size)</li> <li>The pipe tubing can be mounted and removed by one-touch operation.</li> </ul>	13-10-4
<b>Vacuum pad</b> <i>Series ZP</i>	A variety of models (with or without a buffer), pad shapes (flat, flat with ribs, deep, and bellows shape), pad diameters (ø2 to ø250) ø150 and above on special order	13-11-2
<b>Free mount cylinder for vacuum</b> <i>Series ZCUK</i>	In the rectangular, compact cylinder Series CU with a high level of mounting precision, a vacuum passage is provided in the rod to facilitate the mounting of a vacuum pad and to save space.	13-12-2
<b>Vacuum switch</b> <i>Series ZS</i>	Digital pressure switch/ZSE Diaphragm type pressure switch/ZSM1 Adsorption confirmation switch for small diameter/ZSP1	Refer to Best Pneumatics Vol. 16.

## Single Unit System

Equipment such as an ejector is configured as an individual unit. Thus, it is possible to create a flexible system configuration in which the circuit composition and the mounting locations can be selected as desired.

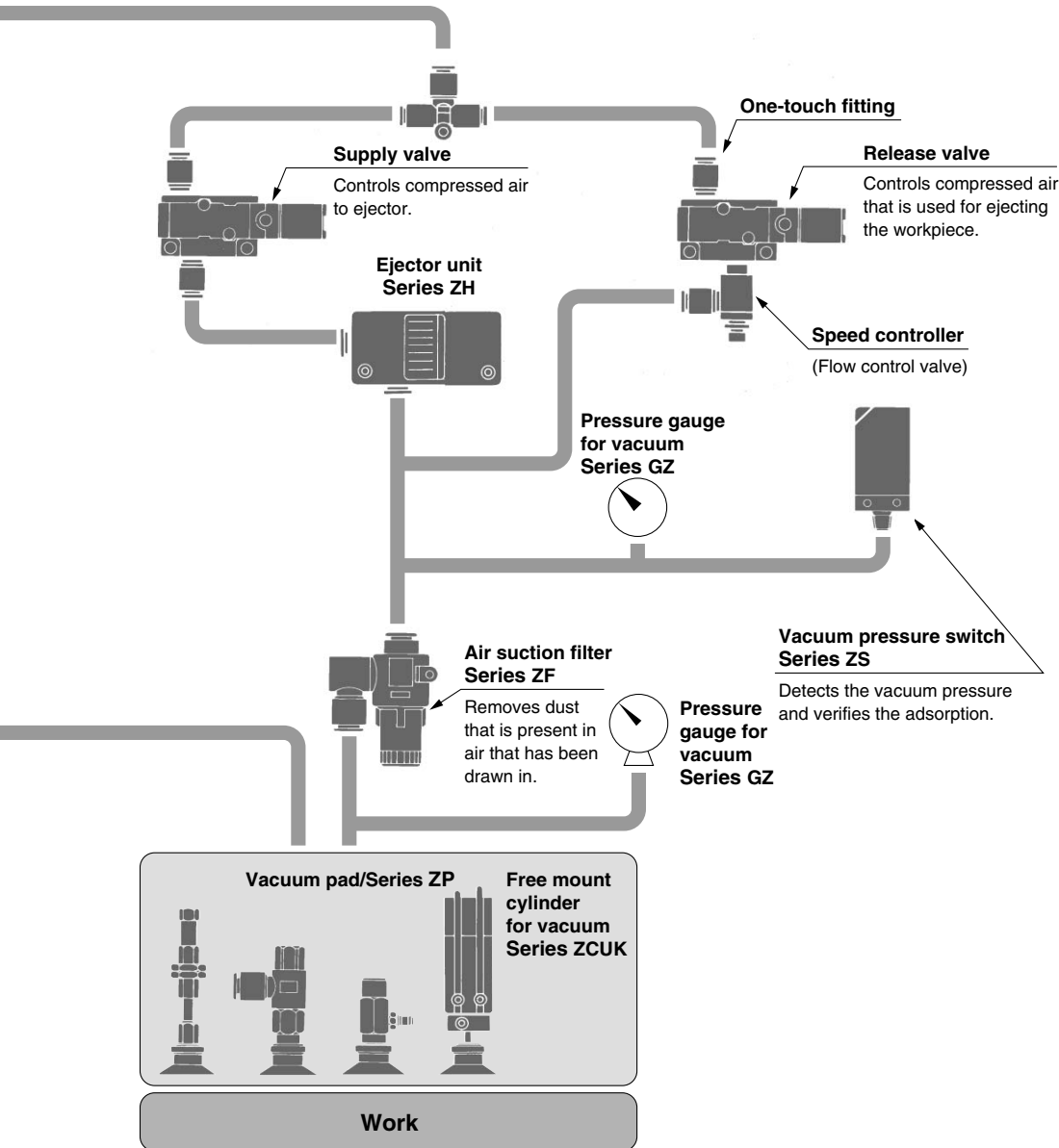

## Other Equipment

	Description	Page
<b>Other equipment for vacuum system</b>	Vacuum regulator/Electronic vacuum regulator/Directional control equipment/Pressure gauge for vacuum/Fitting & Tubing/Flow control equipment/Vacuum accessory equipment	13-14-2
<b>Related products</b>	Air filter/Regulator/Filter regulator/Mist separator	13-14-7

# Adsorption Transfer System for Vacuum Pump

Equipment (vacuum switching valve, vacuum release valve, throttle valve, vacuum pressure switch, and filter) that is needed for controlling the vacuum pressure has been integrated to achieve efficient assembly work and a compact design.

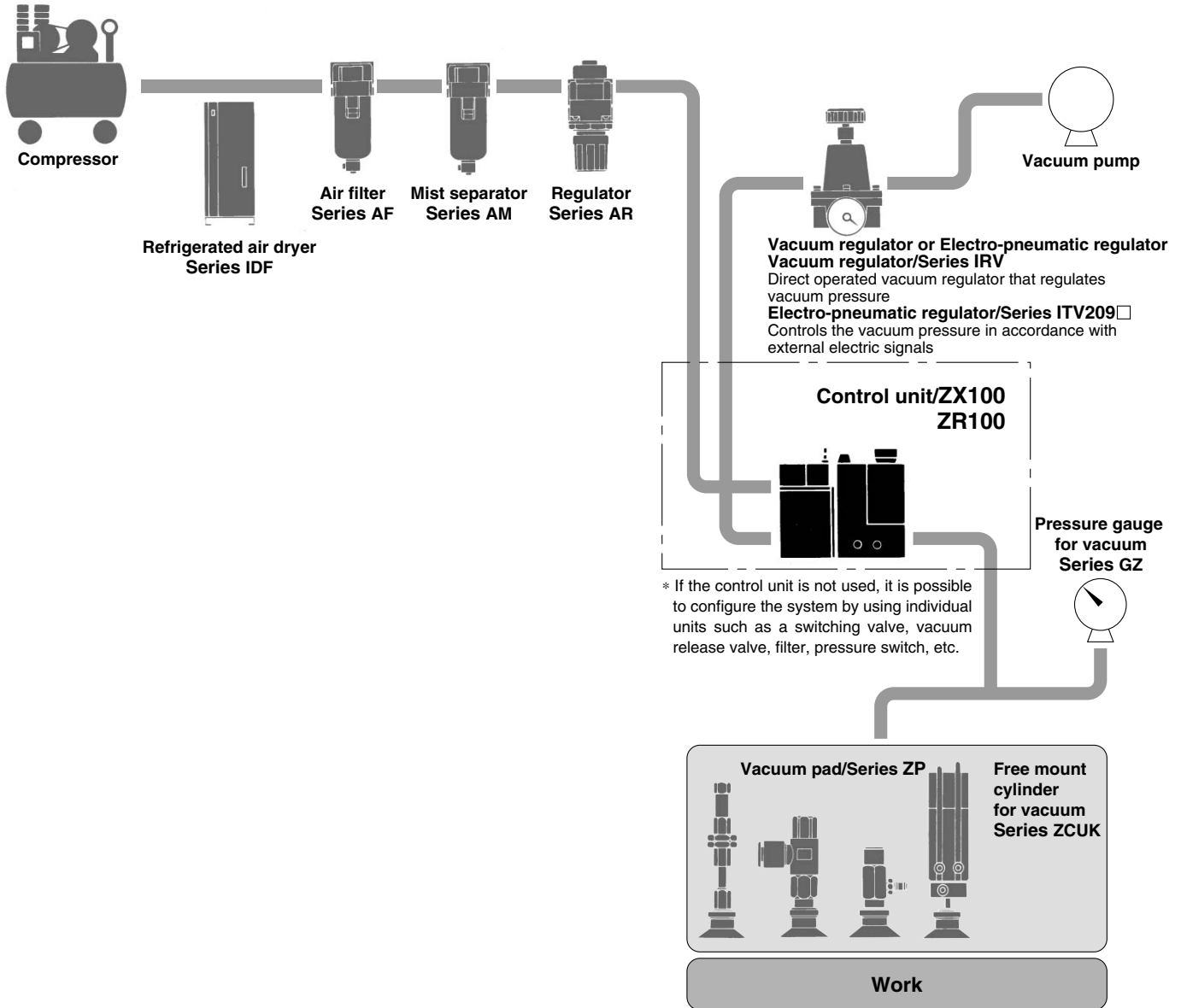





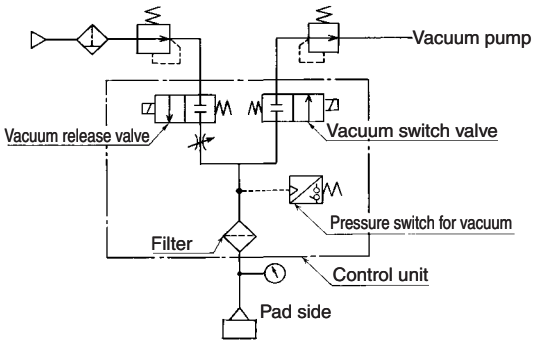

Control unit/Circuit



Vacuum Pump System Component Equipment

Vacuum Pump System Component Equipment		Component equipment				
Control unit	Application	Vacuum switching valve	Vacuum release valve	Vacuum pressure switch	Filter	Page
<b>Series ZX100</b>  <ul style="list-style-type: none"> <li>• Effective area of vacuum switch valve is 3 mm<sup>2</sup>.</li> <li>• Necessary functions can be combined through modular design.</li> </ul>		●	●	●	●	13-2-40
<b>Series ZR100</b>  <ul style="list-style-type: none"> <li>• Double solenoids provide a self-holding function.</li> <li>• Effective area of vacuum switch valve is 8.2 mm<sup>2</sup>.</li> <li>• Necessary functions can be combined through modular design.</li> </ul>		●	●	●	●	13-3-32

Other Equipment		
Description	Application	Page
<b>Vacuum regulator</b> <b>Series IRV</b> 	Direct operated vacuum pressure adjustment valve that regulates the vacuum pressure.	13-14-2
<b>Electro-pneumatic regulator</b> <b>Series ITV209</b> □ 	Controls the vacuum pressure in accordance with external electric signals.	13-14-3



# Vacuum Equipment Model Selection

When an ejector and a vacuum pump are used for picking a workpiece, the picking (and discharge) response times and the vacuum pressures during adsorption vary in accordance with piping conditions and the types of workpieces. Thus, an effective utilization of the vacuum system can be achieved by selecting the proper vacuum equipment.

## Selection Step

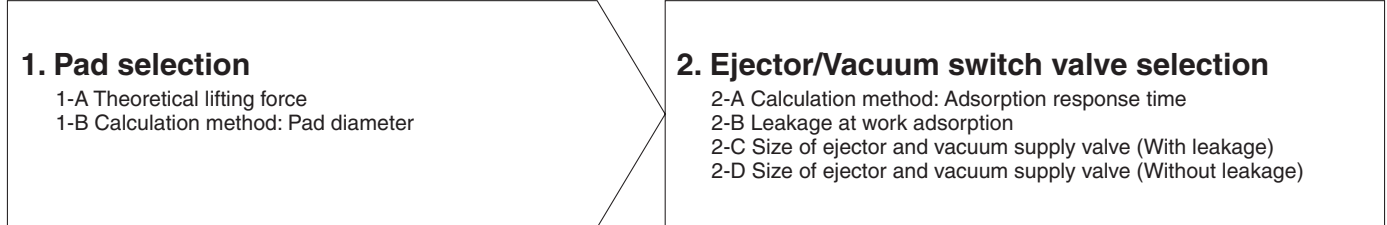

## Selection Step 1 Pad Selection

The pad diameter is found by means of a pad lift calculation. The calculated value should be used for reference and confirmed by actual adsorption tests when necessary. In the lift calculation, consideration should be given to the weight of the workpiece, forces due to acceleration during movement (lifting, stopping, turning, etc.) and a sufficient safety margin should be allowed. An additional margin should also be allowed when determining the number and arrangement of pads.

### 1-A Theoretical Lifting Force

The theoretical lifting force of a pad can be found by calculation or from the theoretical lifting force table.

#### Calculation

$$W = P \times S \times 0.1 \times \frac{1}{t}$$

- W : Lifting force (N)
- P : Vacuum pressure (kPa)
- S : Pad area (cm<sup>2</sup>)
- t : Safety factor  
Horizontal lifting: 4 or more  
Vertical lifting: 8 or more

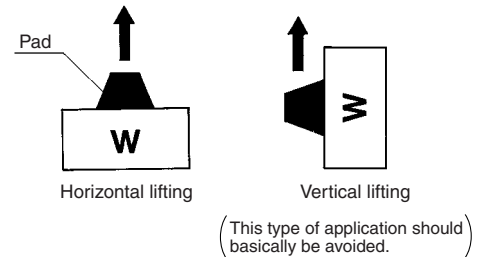

#### Theoretical Lifting Force

The theoretical lifting force (not including the safety factor) is found from the pad diameter and vacuum pressure. The required lifting force is then found by dividing the theoretical lifting force by the safety factor.

$$\text{Lifting force} = \text{Theoretical lifting force} \div t$$

### (1) Theoretical Lifting Force (Theoretical lifting force = P x S x 0.1) (N)

Pad diameter (mm)	2004	3507	4010	ø2	ø4	ø6	ø8	ø10	ø13	ø16	ø20	ø25	ø32	ø40	ø50	
Pad area (cm <sup>2</sup> )	0.07	0.21	0.36	0.031	0.126	0.283	0.503	0.785	1.33	2.01	3.14	4.91	8.04	12.6	19.6	
Vacuum pressure (kPa)	-85	0.60	1.78	3.06	0.264	1.07	2.41	4.28	6.67	11.3	17.1	26.7	41.7	68.3	107	167
	-80	0.56	1.68	2.88	0.248	1.01	2.26	4.02	6.28	10.6	16.1	25.1	39.3	64.3	101	157
	-75	0.53	1.57	2.70	0.233	0.945	2.12	3.77	5.89	9.98	15.1	23.6	36.8	60.3	94.5	147
	-70	0.49	1.47	2.52	0.217	0.882	1.98	3.52	5.50	9.31	14.1	22.0	34.4	56.3	88.2	137
	-65	0.46	1.36	2.34	0.202	0.819	1.84	3.27	5.10	8.65	13.1	20.4	31.9	52.3	81.9	127
	-60	0.42	1.26	2.16	0.186	0.756	1.70	3.02	4.71	7.98	12.1	18.8	29.5	48.2	75.6	118
	-55	0.39	1.15	1.98	0.171	0.693	1.56	2.77	4.32	7.32	11.1	17.3	27.0	44.2	69.3	108
	-50	0.35	1.05	1.80	0.155	0.630	1.42	2.52	3.93	6.65	10.1	15.7	24.6	40.2	63.0	98.0
	-45	0.32	0.94	1.62	0.140	0.567	1.27	2.26	3.53	5.99	9.05	14.1	22.1	36.2	56.7	88.2
-40	0.28	0.84	1.44	0.124	0.504	1.13	2.01	3.14	5.32	8.04	12.6	19.6	32.2	50.4	78.4	

## 1-B Finding the Pad Diameter

A pad diameter which accounts for a safety factor based upon the workpiece lifting method (horizontal or vertical), can be selected by using the calculation formula or the selection graphs (graphs 1, 2 below).

### Calculation

$$\phi D = \sqrt{\frac{4}{3.14} \times \frac{1}{P} \times \frac{W}{n} \times t \times 1000}$$

$\phi D$ : Pad diameter (mm)

$n$ : Number of pads per workpiece

$W$ : Lifting force (N)

$P$ : Vacuum pressure (kPa)

$t$ : Safety factor horizontal lifting: 4 or more

vertical lifting: 8 or more

### Selection Graph

After establishing the workpiece weight, number of pads to be used, and the vacuum pressure when adsorbing the workpiece, the pad diameters for horizontal lifting and vertical lifting can be found by means of using graphs (1) and (2).

**Selection Graph (1)-1 Pad Diameter Selection Graph by Lifting Force Horizontal Lifting (ø2 to ø50)**

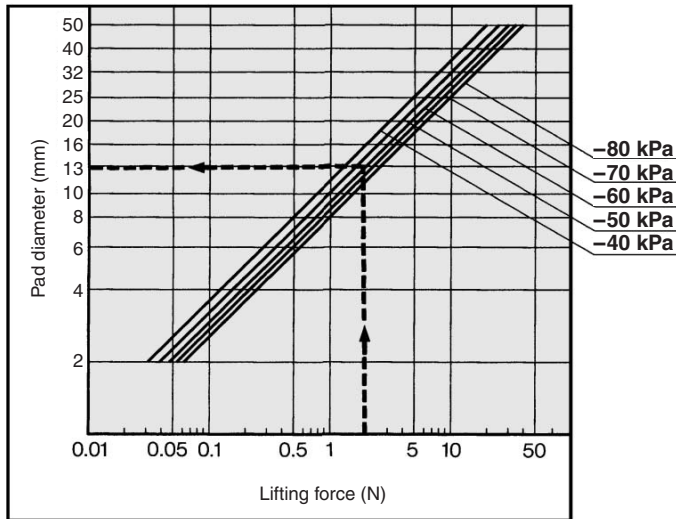

**Selection Graph (2)-1 Pad Diameter Selection Graph by Lifting Force Vertical Lifting (ø2 to ø50)**

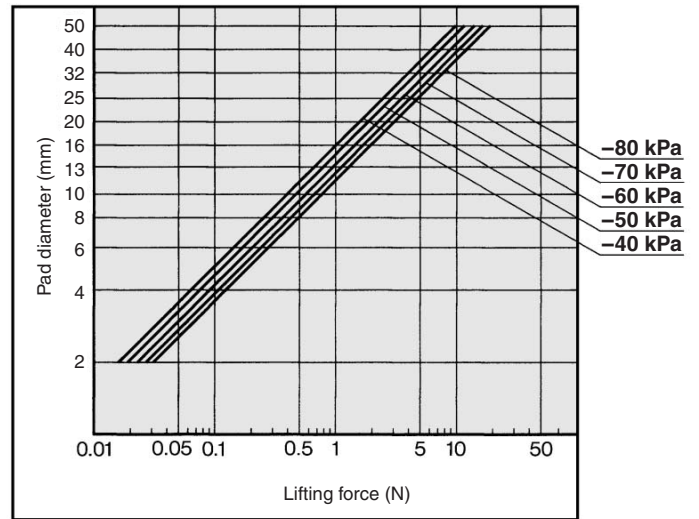

**Selection Graph (1)-2 Pad Diameter Selection Graph by Lifting Force Horizontal Lifting (ø50 to ø250)**

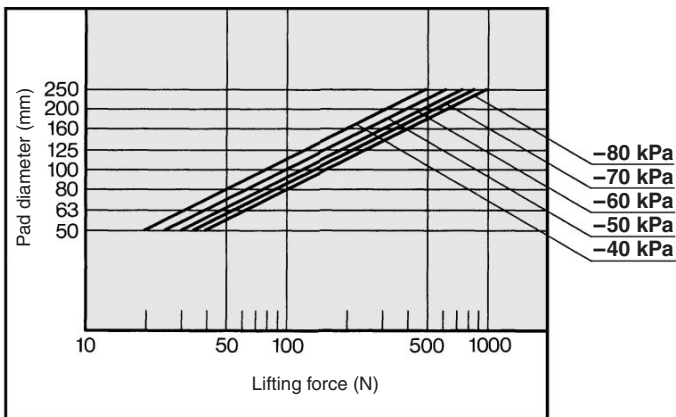

**Selection Graph (2)-2 Pad Diameter Selection Graph by Lifting Force Vertical Lifting (ø50 to ø250)**

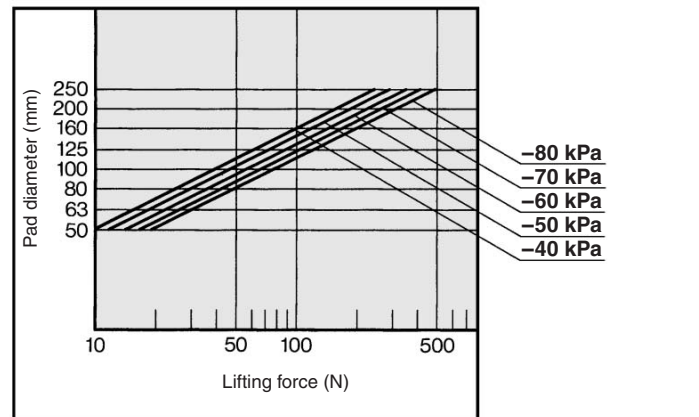

### How to read the graph

Example: Workpiece weight 1 kg (Lifting force: 9.8 N)  
 : Conditions/Number of pads: 5 pcs.  
 Vacuum pressure -60 kPa  
 Horizontal lifting

### <Selection procedure>

From the conditions at the left, the lifting force per pad: 9.8 N ÷ 5 pcs. = 2 N, and for horizontal lifting, selection is made from graph (1)-1. Then, extending the intersection point of the lifting force 2 N and with a vacuum pressure of -60 kPa to the left, a pad diameter of 13 mm is obtained. Therefore, a pad diameter of 13 mm or greater should be selected.

## Selection Step 2 Selection of Ejector and Vacuum Switching Valve

### 2-A Adsorption Response Time

When a pad is used for the adsorption transport of a workpiece, the approximate adsorption response time can be obtained (the length of time it takes for the pad's internal vacuum pressure to reach the pressure that is required for adsorption after the supply valve (vacuum switching valve) has been operated). An approximate adsorption response time can be obtained through formulas and selection graphs (3) and (4).

#### Vacuum System Circuit

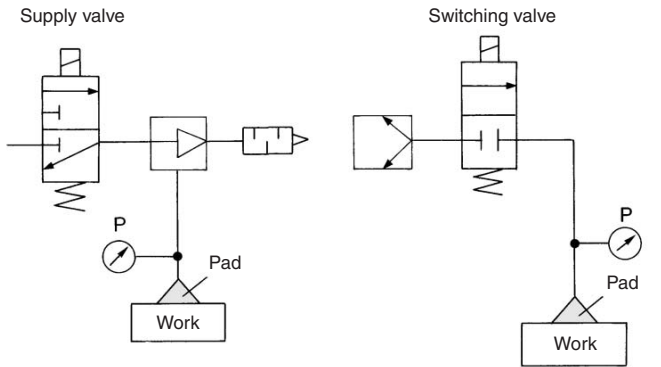

#### Vacuum Pressure and Response Time after Supply Valve (switching valve) is Operated

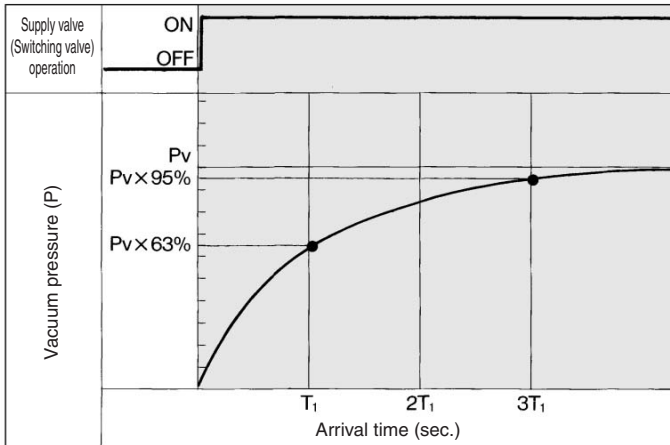

$P_v$ : Last vacuum pressure  
 $T_1$ : Arrival time to 63% of last vacuum pressure  $P_v$   
 $T_2$ : Arrival time to 95% of last vacuum pressure  $P_v$

#### Calculation

Adsorption response times  $T_1$  and  $T_2$  can be obtained through the formulas given below.

$$\text{Adsorption response time } T_1 = \frac{V \times 60}{Q}$$

$$\text{Adsorption response time } T_2 = 3 \times T_1$$

#### Piping capacity

$$V = \frac{3.14}{4} D^2 \times L \times \frac{1}{1000} (\ell)$$

$T_1$ : Arrival time to 63% of last vacuum pressure  $P_v$

$T_2$ : Arrival time to 95% of last vacuum pressure  $P_v$

$Q_1$ : Average adsorption flow  $\ell/\text{min}$  (ANR)

Calculation of average adsorption flow

• **Ejector**  
 $Q_1 = (1/2 \text{ to } 1/3) \times \text{Ejector Max. adsorption flow } \ell/\text{min}$  (ANR)

• **Vacuum pump**  
 $Q_1 = (1/2 \text{ to } 1/3) \times 11.1 \times \text{Effective area of vacuum pump}$  ( $\text{mm}^2$ )

$D$ : Piping diameter (mm)

$L$ : Length from ejector and switch valve to pad (m)

$V$ : Piping capacity from ejector and switching valve to pad ( $\ell$ )

$Q_2$ : Max. flow from ejector and switching valve to pad by piping system  
 $Q_2 = S \times 11.1 \ell/\text{min}$  (ANR)

$Q$ : Smaller one between the  $Q_1$  and  $Q_2$   $\ell/\text{min}$  (ANR)

$S$ : Effective area of piping ( $\text{mm}^2$ )

#### Selection Graph

##### 1. Tubing piping capacity

Piping capacity from ejector and switching valve at vacuum pump to pad can be found from selection graph (3).

##### Selection Graph (3) Tubing I.D. Piping Capacity

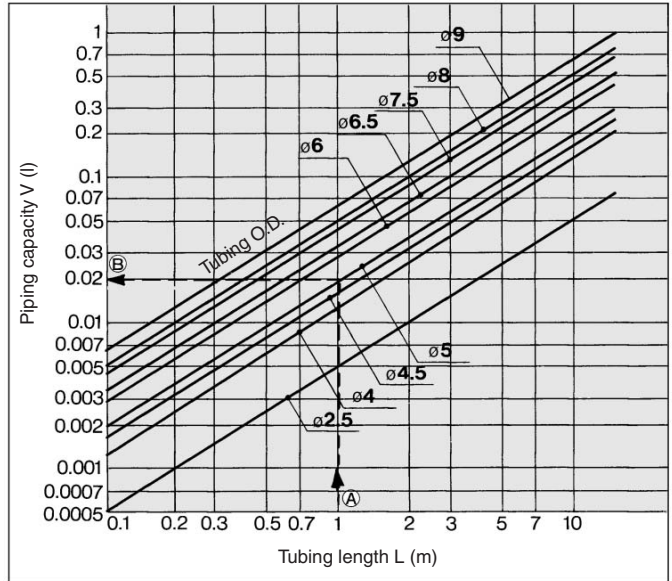

#### How to read the graph

Example: For obtaining the volume of tubing with bore size of  $\phi 5$  mm and 1 meter length.

#### Selection Procedure

By extending leftward from the point at which the 1 meter tubing length on the horizontal axis intersects the line for a tubing's bore size of  $\phi 5$  mm, the piping volume approximately equivalent to 0.02  $\ell$  can be obtained, on the vertical axis.

**Piping capacity:**  $\cong 0.02 \ell$

##### 2. Effective area of tubing

Effective area of tubing from graph below

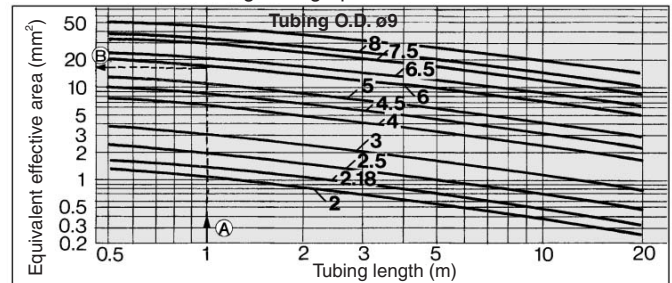

#### How to read the graph

Example: Tubing size  $\phi 8/\phi 6$ , 1 m

#### Selection Procedure

From the point of intersection of tubing length 1 m of lateral axis and tubing I.D.  $\phi 6$  mm, the equivalent effective area at vertical axis can be found as approx. 18  $\text{mm}^2$ .

**Equivalent effective area:**  $\cong 18 \text{ mm}^2$

### 3. Obtaining the adsorption response times

By operating the supply valve (switching valve) that controls the ejector (vacuum pump), the adsorption response times  $T_1$  and  $T_2$  that elapsed before the prescribed vacuum pressure is reached can be obtained from the selection graph (4).

Selection Graph (4) (Adsorption Response Time)

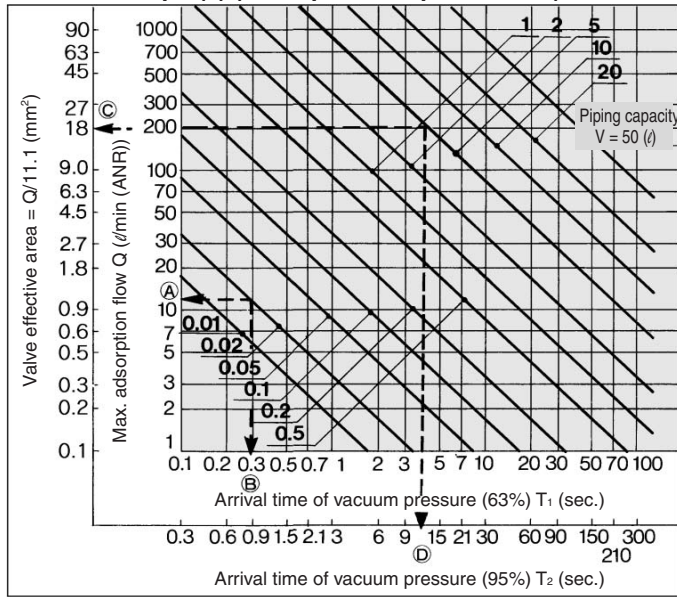

\* Conversely, the size of the ejector or the size of the switching valve of the vacuum pump system can be obtained from the adsorption response time.

### How to read the graph

**Example 1:** For obtaining the adsorption response time until the pressure in the piping system with a piping volume of 0.02 l is discharged to 63% ( $T_1$ ) of the final vacuum pressure through the use of the vacuum ejector ZH07□S with a maximum suction flow rate of 12 l/min (ANR).

#### Selection Procedure

From the point at which the vacuum ejector's maximum vacuum suction flow rate of 12 l/min (ANR) and the piping volume of 0.02 l intersect, the adsorption response time  $T_1$  that elapses until 63% of the maximum vacuum pressure is reached can be obtained. (Sequence in selection graph (4), A→B)  $T_1$ : ≙ **0.3 seconds**.

**Example 2:** For obtaining the discharge response time until the internal pressure in the 5 l tank is discharged to 95% ( $T_2$ ) of the final vacuum pressure through the use of a valve with an effective area of 18 mm<sup>2</sup>.

#### Selection Procedure

From the point at which the valve's effective area of 18 mm<sup>2</sup> and the piping volume of 5 l intersect, the discharge response time ( $T_2$ ) that elapses until 95% of the final vacuum pressure is reached can be obtained. (Sequence in selection graph (4), C→D)  $T_2$ : ≙ **12 seconds**.

## 2-B Leakage at Work Adsorption

### Leakage

Even if the pad picks up a workpiece, air could be drawn in depending on the type of workpiece. As a result, the vacuum pressure in the pad becomes reduced and the amount of vacuum that is necessary for adsorption cannot be attained.

When this type of workpiece must be handled, it is necessary to select the proper size of the ejector and the vacuum switching valve by taking into consideration the amount of air that could leak through the workpiece.

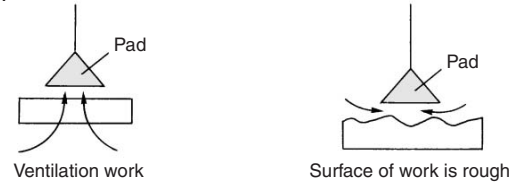

### Leakage from Effective Area of Work

**Leakage**  $Q_L = 11.1 \times S_L$   
 $Q_L$ : Leakage l/min (ANR)  
 $S_L$ : Effective area between work and pad, and work opening area (mm<sup>2</sup>)

### Leakage from Adsorption Test

As described in the illustration below, pick up the workpiece with the ejector, using an ejector, pad and a vacuum gauge. At this time, read vacuum pressure  $P_1$ , obtain the suction flow rate from the flow characteristics graph for the ejector that is being used, and render this amount as the leakage of the workpiece.

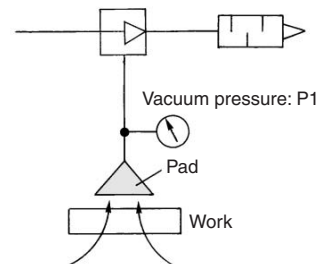

**Exercise:** Using a supply pressure of 0.45 MPa, when the ejector (ZH07□S) picks up a workpiece that leaks air, the vacuum gauge indicated a pressure of -53 kPa. Calculate the leakage volume from the workpiece.

#### Selection Procedure

When the suction flow rate of -53 kPa is obtained from the ZH07DS flow characteristics graph, the leakage volume is 5 l/min (ANR). (A→B→C)

**Leakage:** ≙ **Adsorption flow (5 l/min) (ANR)**

### ZH07BS/ZH07DS

#### Exhaust Characteristics

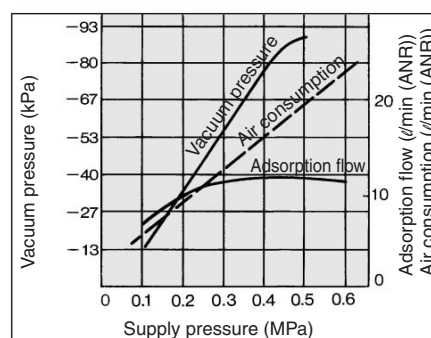

#### Flow Characteristics

Supply pressure (0.5 MPa)

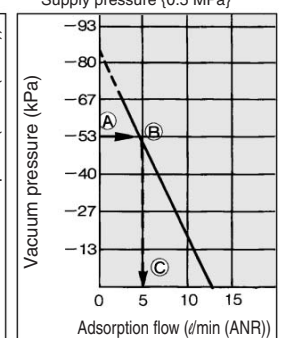



## Selection Step 2 Selection of Ejector and Vacuum Switching Valve

### 2-C Sizing Ejector and Vacuum Switching Valve (with Leakage)

If there is leakage through a workpiece, the necessary size of the ejector and the vacuum switching valve can be obtained by adding the leakage volume to the maximum suction flow rate.

#### Calculation

##### 1. Average adsorption flow to achieve adsorption response time

$$Q = \frac{V \times 60}{T_1} + Q_L$$

$$T_2 = 3 \times T_1$$

**Q** : Average suction flow rate  $\ell$ /min (ANR)

**V** : Piping capacity ( $\ell$ )

**T<sub>1</sub>** : Arrival time to stable Pv 63% after adsorption (sec.)

**T<sub>2</sub>** : Arrival time to stable Pv 95% after adsorption (sec.)

**Q<sub>L</sub>** : Leakage at work adsorption  $\ell$ /min (ANR)

##### 2. Max. suction flow rate

$$Q_{max} = (2 \text{ to } 3) \times Q \text{ } \ell\text{/min (ANR)}$$

#### Selection Procedure

##### • Ejector

Select the ejector with the greater maximum suction flow rate from the  $Q_{max}$  indicated above.

##### • Direct operation valve

$$\text{Effective area } S = \frac{Q_{max}}{11.1} \text{ (mm}^2\text{)}$$

\* Select a valve (solenoid valve) having an effective area that is greater than that of the effective area formula given above from the related equipment (P. 13-14-4).

#### Selection Graph

##### 1. Tubing capacity

Using selection graph (3) (P. 13-1-12) "Tubing I.D. Piping Capacity", make a selection in the same manner as indicated in "When no leakage occurs when picking up a workpiece".

##### 2. Max. adsorption flow $Q_{max}$

Using selection graph (4) "Response Time", obtain the maximum suction flow rate  $Q$  that does not contain the leakage amount  $Q_L$ , based on the set adsorption response times ( $T_1$ ,  $T_2$ ) and the tubing volume.

$$\text{Max. adsorption flow } Q_{max} = Q + (3 \times Q_L)$$

**Q** : Max. adsorption flow from selection graph (4) "Response time" on (P. 13-1-13)

**Q<sub>L</sub>** : Leakage volume  $\ell$ /min (ANR) (P. 13-1-13) (2) B if there is leakage when adsorbing up a workpiece

#### Selection Procedure

##### • Ejector

Select an ejector having a greater maximum suction flow rate than that of  $Q_{max}$  given above. During the selection, verify the pad's lift force because the vacuum pressure after adsorption will be lower than the maximum vacuum pressure due to the leakage volume  $Q_L$   $\ell$ /min (ANR).

#### Example: ZH10□S

(Supply pressure 0.45 MPa)  
If the leakage volume  $Q_L$  is 5  $\ell$ /min (ANR), the vacuum pressure after adsorption will be -73 kPa.  
(A → B)

Flow Characteristics

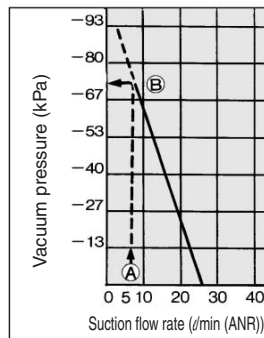

##### • Vacuum switch valve

Using selection graph (4) (P. 13-1-13), move the maximum suction flow rate  $Q_{max}$  point parallel to the graduation line of the effective area  $S$  of the left valve; then, obtain the effective area of the vacuum switching valve from the intersecting point.

### 2-D Sizing Ejector and Vacuum Switch Valve (without Leakage)

#### Calculation

##### 1. Average suction flow rate

$$Q = \frac{V \times 60}{T_1}$$

$$T_2 = 3 \times T_1$$

**Q** : Average suction flow rate  $\ell$ /min (ANR)

**V** : Piping capacity

**T<sub>1</sub>** : Arrival time to stable Pv 63% after adsorption (sec.)

**T<sub>2</sub>** : Arrival time to stable Pv 95% after adsorption (sec.)

##### 2. Max. adsorption flow

$$Q_{max} = (2 \text{ to } 3) \times Q \text{ } \ell\text{/min (ANR)}$$

#### Selection Procedure

##### • Ejector

Select the ejector with the greater maximum suction flow rate from the  $Q_{max}$  max. indicated above.

##### • Vacuum switch valve

$$\text{Effective area } S = \frac{Q_{max}}{11.1} \text{ (mm}^2\text{)}$$

\* Select a valve (solenoid valve) having an effective area that is greater than that of the effective area formula given above from the related equipment (P. 13-14-4).

#### Selection Graph

##### 1. Tubing capacity

Using tubing capacity selection graph (3) (P. 13-1-12) "Tubing I.D. Piping Capacity", make a selection in the same manner as indicated in "When no leakage occurs when picking up a workpiece".

##### 2. Max. adsorption flow $Q_{max}$

Using selection graph (4) "Response Time", obtain the maximum suction flow rate  $Q$  based on the set adsorption response times ( $T_1$ ,  $T_2$ ) and the tubing volume.

#### Selection Procedure

##### • Ejector

Select an ejector having a greater maximum suction flow rate than that of  $Q_{max}$  given above.

##### • Vacuum switch valve

Using valve selection graph (4), move the maximum suction flow rate  $Q_{max}$  point parallel to the graduation line of the effective area  $S$  of the left valve; then, obtain the effective area of the vacuum switching valve from the intersecting point.

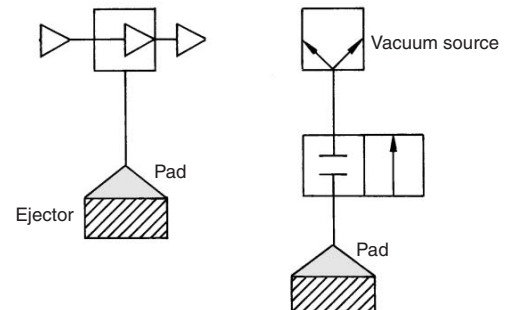

**⚠ Caution**

**Precautions on Vacuum Equipment Selection**

As a countermeasure for power outages, select a supply valve that is normally open or one that is equipped with a self-holding function.

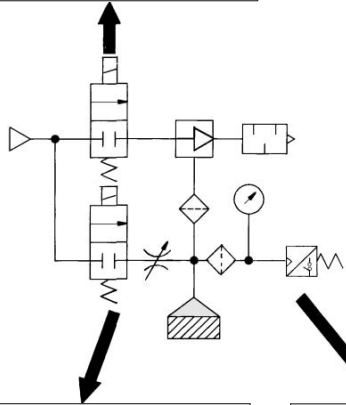

Select a vacuum switching valve that has an effective area that does not reduce the composite effective area consisting of the areas from the pad to the ejector.

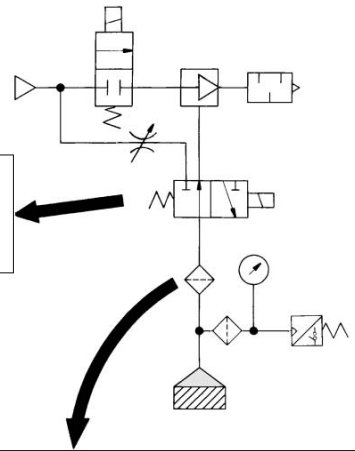

For the vacuum release valve, select a 2-3 port valve with a low vacuum specification. Also, use a needle valve to regulate the release flow rate.

- During the adsorption transport of a workpiece, verification of the vacuum switch is recommended.
- In addition, visually verify the vacuum gauge when handling a heavy or a hazardous item.
- The ZSP1 type is the optimal type for the adsorption/transport of small parts using a suction nozzle with a small diameter.
- Install a filter (Series ZFA-ZFB) before the pressure switch if the ambient air is of low quality.

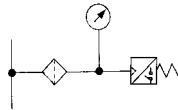

Use a suction filter (Series ZFA-ZFB) to protect the switching valve and to prevent the ejector from becoming clogged. Also a suction filter must be used with the Series ZX, ZR, and Series ZM in a dusty environment. If only the unit's filter is used, it will become clogged quickly.

**⚠ Caution**

**Precautions on Matching with Vacuum Circuit**

Ejector and number of pads		Vacuum pump and number of pads	
<p>Ideally, one pad should be used for each ejector.</p>	<p>When more than one pad is attached to a single ejector, if one of the workpieces becomes detached, the vacuum pressure will drop, causing other workpieces to become detached. Therefore, the countermeasures listed below must be taken.</p> <ul style="list-style-type: none"> <li>• Adjust the needle valve to minimize the pressure fluctuation between adsorption and non-adsorption operations.</li> <li>• Provide a vacuum switching valve to each individual pad to minimize the influences on other pads if an adsorption error occurs.</li> </ul>	<p>Ideally, one pad should be used for each ejector.</p>	<p>When more than one pad is attached to a single vacuum line, take the countermeasures listed below.</p> <ul style="list-style-type: none"> <li>• Adjust the needle valve to minimize the pressure fluctuation between adsorption and non-adsorption operations.</li> <li>• Include a tank and a vacuum pressure reduction valve (vacuum pressure regulator valve) to stabilize the source pressure.</li> <li>• Provide a vacuum switching valve to each individual pad to minimize the influences on other pads if an adsorption error occurs.</li> </ul>

## ⚠ Caution

### Ejector Selection

There are 2 types of ejector flow rate characteristics: the high vacuum (S type) and the high flow rate (L type). During the selection, pay particular attention to the vacuum pressure when adsorbing workpieces that leak.

#### High Vacuum Type Flow Characteristics/ZH13□S

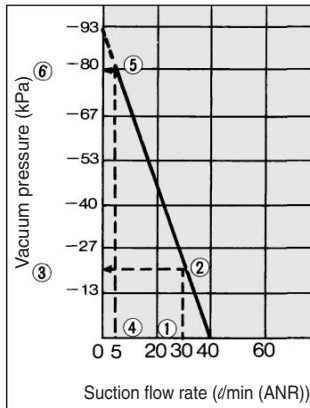

#### High Flow Type Flow Characteristics/ZH13□L

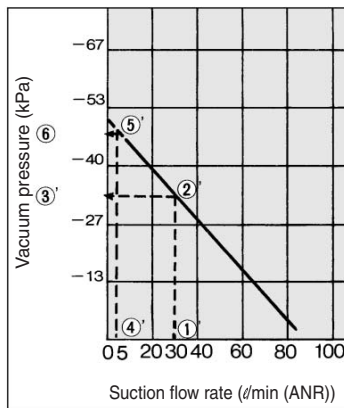

The vacuum pressure varies in accordance with the leakage volumes indicated in the above diagrams.

If the leakage volume is 30 l/min (ANR), the vacuum pressure of the S type is -20 kPa ① → ② → ③, and for the L type it is -33 kPa ①' → ②' → ③'. If the leakage volume is 5 l/min (ANR), the vacuum pressure of the S type is -80 kPa ④ → ⑤ → ⑥, and for the L type it is -47 kPa ④' → ⑤' → ⑥'. Thus, if the leakage volume is 30 l/min (ANR) the L type can attain a higher vacuum pressure, and if the leakage volume is 5 l/min (ANR), the S type can attain a higher vacuum pressure.

Thus, during the selection process, make sure to take the flow characteristics of the high vacuum type (S type) and the high flow rate type (L type) into consideration in order to select the type that is optimal for your application.

### Ejector Nozzle Diameter Selection

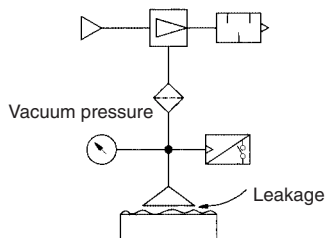

If a considerable amount of leakage occurs between the workpiece and the pad, resulting in incomplete adsorption, or to shorten the adsorption transport time, select an ejector nozzle with a larger diameter from the Series ZH, ZM, ZR, or ZL.

### Manifold Use

#### Individual exhaust

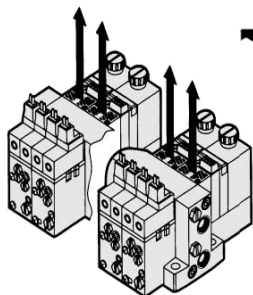

If there are a large number of ejectors that are linked on a manifold and operate simultaneously, use the built-in silencer type or the port exhaust type.

#### Centralized exhaust

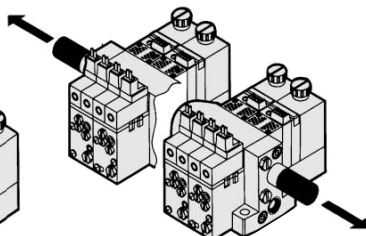

If there are a large number of ejectors that are linked on a manifold, which exhaust collectively, install a silencer at both ends. If the exhaust must be discharged outdoors through piping, make sure that the diameter of the piping is large enough that its back pressure will not affect the operation of the ejectors.

### Pad Selection

(Set the operating pressure below the pressure that has been stabilized after adsorption.) Determine the pad diameter in accordance with the operating pressure.

During the selection of a pad, keep in mind that the vacuum pressure during the adsorption of a workpiece that leaks becomes lower than the maximum vacuum pressure.

### Vacuum Line Equipment Selection

Determine the volume of the suction filter and the effective area of the switching valve in accordance with the maximum suction flow rate of the ejector and the vacuum pump. Make sure that the effective area is greater than the value that has been obtained through the formula given below. (If the devices are connected in series in the vacuum line, their effective areas must be combined.)

$$S = Q_{max}/11.1 \quad S: \text{Effective area (mm}^2\text{)}$$

$$Q_{max}: \text{Max. adsorption l/min (ANR)}$$

### Vacuum Switch (Series ZS), Vacuum Gauge (Series GZ)

When adsorbing and transporting a workpiece, verify at the vacuum switch as much as possible (In addition, visually verify the vacuum gauge, especially when handling a heavy or a hazardous item.).

When picking an electronic part or a small precision part, if the suction nozzle is approximately  $\phi 1$ , the difference in pressure between ON and OFF becomes small (although this will also depend on the capacity of the ejector and the vacuum pump). In such a case, it will be necessary to use the adsorption verification switch ZSP1, which has a small hysteresis and high precision. Conversely, it cannot be detected by an ejector with a large suction capacity. Therefore, use an appropriate pressure switch. Furthermore, it will become necessary to stabilize the pressure of the ejector and the vacuum pump.

### Air Suction Filter (Series ZFA, ZFB)

- To protect the switching valve and the ejector from becoming clogged, a suction filter in the vacuum circuit is recommended.
- When using the Series ZX, ZR, and ZM in a dusty environment, the unit's filter will become clogged quickly, so it is recommended that the Series ZFA and ZFB be used concurrently.



## Vacuum Pad Selection

### Safety

Because suction is applied to an object during a vacuum adsorption transport, there is a possibility of dropping the object depending on the conditions. Thus, everything should be designed with safety as the number one priority in order to achieve a system design with an excellent margin of safety.

### Mounting Position

As a rule, the unit must be installed horizontally. Although a diagonal or a vertical installation should be avoided whenever possible, if the unit must be installed in such a manner, be certain to guarantee absolute safety.

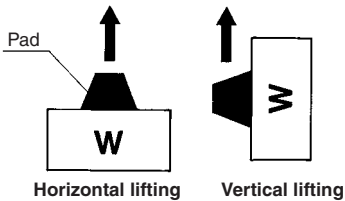

### Impact to Pad

When pushing a pad to a workpiece, make sure not to apply an impact or a large force which would lead to premature deformation, cracking, or wearing of the pad. Therefore, the pad should be pushed against the workpiece to the extent that its skirt portion deforms or that its ribbed portion comes into slight contact with the workpiece. Especially, when using a smaller diameter pad, make sure to locate it correctly.

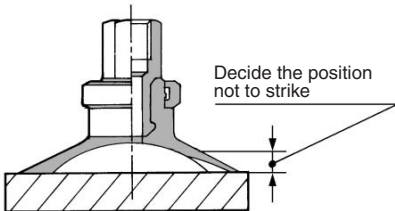

### Balance of Pad and Work

Make sure that the pad's suction surface is not larger than the surface of the workpiece to prevent vacuum leakage and unstable picking.

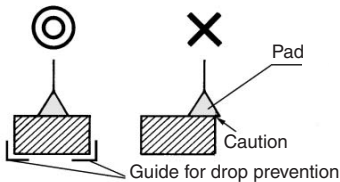

If multiple pads are used for transporting a flat object with a large surface area, properly allocate the pads to maintain balance. Also make sure that the pads are aligned properly to prevent them from becoming disengaged along the edges.

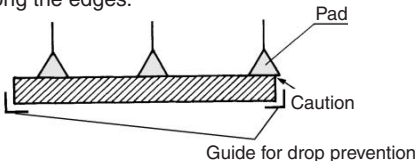

Provide an auxiliary device (example: a guide for preventing the workpieces from dropping) as necessary.

### Lifting Force, Moment, Horizontal Force

To lift a workpiece vertically, make sure to take into consideration the acceleration rate, wind pressure, impact, etc., in addition to the weight of the workpiece. (Refer to Fig. 1) Because the pads are susceptible to moments, mount the pad so as not to allow the workpiece to create a moment. (Refer to Fig. 2)

When a workpiece that is suspended horizontally is moved laterally, the workpiece could shift depending on the extent of the acceleration rate or the size of the friction coefficient between the pad and the workpiece. Therefore, the acceleration rate of the lateral movement must be minimized. (Refer to Fig. 3)

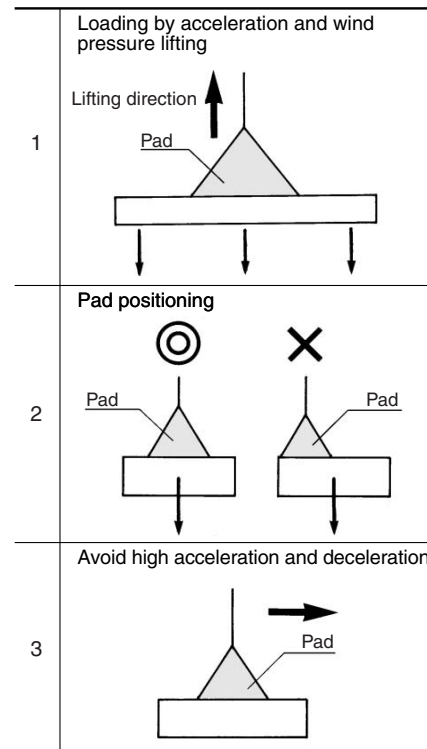

### Unsteady Distance between Pad and Work

If the pad and the workpiece cannot be positioned properly, such as when picking a workpiece having an uneven height, use a built-in spring type pad with a buffer. This type of pad acts as a cushion between the pad and the workpiece. If it is necessary to further position the pad and the workpiece, use a non-rotating buffer.

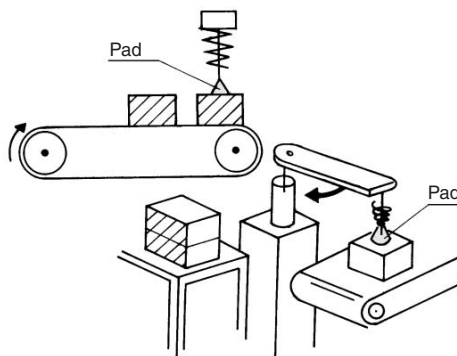

### Porous Work

To pick a permeable workpiece such as paper, select a pad with a small diameter that is sufficient to lift the workpiece. Because a large amount of air leakage could reduce the pad's suction force, it may be necessary to increase the capacity of the vacuum pump or enlarge the effective area of the piping passage.

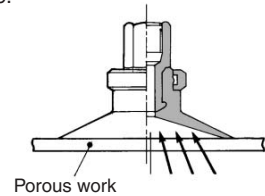

### Flat Plate Work

When a workpiece with a large surface area such as sheet glass or PCB is suspended, the workpiece could move in a wavelike motion if a large force is applied by wind pressure or by an impact. Therefore, it is necessary to ensure the proper allocation and size of pads.

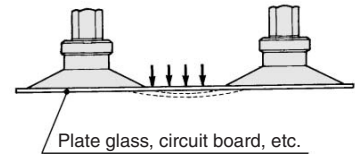

### Pad Form Selection by Work

To use an appropriate pad, select the shape of the pad in accordance with the shape and the material of the workpiece.

<b>Flat</b> (For a workpiece that has a flat surface and free of deformation.)	
<b>Flat with ribs</b> (For a workpiece that is susceptible to deformation.)	
<b>Deep</b> (For a workpiece with a curved surface.)	
<b>Bellows</b> (For a workpiece that does not have a space for a buffer, or for a workpiece with a diagonal surface.)	

### Soft Work

If a soft workpiece such as vinyl, paper, or thin sheet is picked up, the vacuum pressure could cause the workpiece to deform or wrinkle. In such a case, it will be necessary to use a small pad or a ribbed pad and reduce the vacuum pressure.

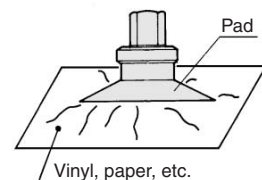









## Vacuum Pad/Example of Work Transfer

### Material

Material	Application
NBR	Transport of general work, Corrugated board, Veneer plate, Iron plate and others
Silicon rubber	Semiconductor, Removing from die-casting, Thin work, Food processor
Urethane rubber	Corrugated board, Iron plate, Veneer plate
Fluoro rubber	Chemical work
Conductive NBR	General work of semiconductor (Static electricity resistance)
Conductive silicon rubber	Semiconductor (Static electricity)

### Pad Type

Pad form	Application
Flat 	To be used when adsorption surface of work is flat and not deformed.
Flat with ribs 	To be used when work is likely to deform or in the case of releasing work certainly.
Deep 	To be used when work is curved shape.
Bellows 	To be used when there is not enough space to install buffer or adsorption surface of work is slanted.
Elliptic 	To be used when work has limited adsorption surface or long in length and work is required to locate precisely.
Ball joint type 	To be used when adsorption surface of work is not horizontal.
Long stroke buffer 	To be used when work height is not even or cushioning toward work is required.
Large size buffer 	To be used when work is heavy weight.
Conductive pad 	As one of the countermeasures against the static electricity, rubber material with reduced resistance is used. For antistatic measures

## Glossary of Terms

Terms	Description
(Max.) Adsorption flow	Volume of air taken in by the ejector. The maximum volume is the flow rate of the air that is taken in without having anything connected to the vacuum port.
Maximum vacuum pressure	The maximum value of the vacuum pressure that is generated by the ejector.
Air consumption	The volume of compressed air that is consumed by the ejector.
Standard supply pressure	The optimal supply pressure for operating the ejector.
Exhaust characteristics	The relation between the vacuum pressure and the suction flow rate when the supply pressure to the ejector has been changed.
Flow characteristics	The relation between the vacuum pressure and the suction flow rate with the standard supply pressure supplied to the ejector.
Vacuum pressure switch	The pressure switch that is used for verifying the adsorption of a workpiece.
Adsorption confirmation switch	The switch, based on an air pressure bridge, that is used for verifying the adsorption of a workpiece. It is used when the adsorption pad and the nozzle are extremely small.
(Air) Supply valve	The valve that supplies compressed air to the ejector.
(Vacuum) Release valve	The valve that supplied positive pressure or air to break the vacuum state of the adsorption pad.
Flow adjustment valve	The valve that supplied positive pressure or air that regulates the flow of the air to break the vacuum.
Release pressure	Pressure that is used for breaking the vacuum.
Pilot pressure	Pressure that is used for operating the ejector valve.
External release	The action of breaking the vacuum using externally supplied air instead of using the ejector unit.
Vacuum port	Port for generating vacuum.
Exhaust port	Port for exhausting the air, which was used by the ejector, and the air taken in by vacuum port.
Supply port	Port for supplying the air, which is used by the ejector.
Back pressure	Pressure inside the exhaust port.
Leakage	The entry of air into the vacuum passage, such as from an area between a workpiece and a pad, or between a joint and tubing. The vacuum pressure decreases when leakage occurs.
Response speed	The length of time that elapses from when the supply valve or the switching valve is activated until the pressure switch turns ON. It is also called the adsorption time.
Average suction flow rate	The suction flow rate of the ejector or the pump, which is used for calculating the response speed. It is $\frac{1}{2}$ to $\frac{1}{3}$ of the maximum suction flow rate.
Conductive pad	A pad with a low electrical resistance that is used as an electrostatic prevention measure.
Vacuum pressure	Any pressure below the atmospheric pressure. When the atmospheric pressure is used as a reference, the pressure is presented by -kPa (G), and when the absolute pressure is used as a reference, the pressure is represented by kPa. When referencing a piece of vacuum equipment such as an ejector, the pressure is generally represented by -kPa.
Ejector unit	A device that generates vacuum by means of discharging the compressed air from a nozzle at a high speed, thus utilizing the phenomenon in which the pressure is reduced when the air around the nozzle is sucked.
Air suction filter	The vacuum filter that is provided in the vacuum passage in order to prevent the intrusion of dust into the ejector, the vacuum pump, or peripheral equipment.

**Effective Diameter of Vacuum Pad**

Effective diameter at adsorption is as follows.

**Vacuum Area Diameter (Vacuum pressure: -84 kPa) after Vacuum Suction by Vacuum Pad** (mm)

Part no.	Type	Flat U		Flat with ribs C		Bellows B		Deep D		Large size H		Large size bellows HB	
	Material Size	NBR	Silicon rubber	NBR	Silicon rubber	NBR	Silicon rubber	NBR	Silicon rubber	NBR	Silicon rubber	NBR	Silicon rubber
ZP02**	2	ø2	ø2	—	—	—	—	—	—	—	—	—	—
ZP04**	4	ø4	ø4	—	—	—	—	—	—	—	—	—	—
ZP06**	6	ø5	ø4	—	—	ø5	ø5	—	—	—	—	—	—
ZP08**	8	ø7	ø7	—	—	ø7	ø5	—	—	—	—	—	—
ZP10**	10	ø10	ø9	ø10	ø9	ø8	ø7	ø10	ø10	—	—	—	—
ZP13**	13	ø11	ø11	ø11	ø11	ø8	ø9	—	—	—	—	—	—
ZP16**	16	ø10	ø9	ø13	ø13	ø10	ø9	ø14	ø12	—	—	—	—
ZP20**	20	ø14	ø12	ø15	ø14	ø13	ø13	—	—	—	—	—	—
ZP25**	25	ø14	ø13	ø18	ø17	ø15	ø15	ø19	ø16	—	—	—	—
ZP32**	32	ø13	ø11	ø21	ø20	ø20	ø19	—	—	—	—	—	—
ZP40**	40	ø20	ø17	ø26	ø24	ø26	ø25	ø24	ø24	ø33	ø32	ø29	ø27
ZP50**	50	ø18	ø17	ø33	ø30	ø35	ø33	—	—	ø42	ø42	ø39	ø36
ZP63**	63	—	—	—	—	—	—	—	—	ø49	ø49	ø46	ø45
ZP80**	80	—	—	—	—	—	—	—	—	ø60	ø60	ø57	ø56
ZP100**	100	—	—	—	—	—	—	—	—	ø78	ø78	ø69	ø71
ZP125**	125	—	—	—	—	—	—	—	—	ø102	ø101	ø92	ø91

# Vacuum Ejector Box Type (Built-in Silencer)/Body Ported Type Series ZH

Nozzle diameter:  $\varnothing 0.5$ ,  $\varnothing 0.7$ ,  $\varnothing 1.0$ ,  $\varnothing 1.3$ ,  $\varnothing 1.5$ ,  $\varnothing 1.8$ ,  $\varnothing 2.0$   
 Type S: Standard type  
 L: Large flow type

ZX
ZR
ZM
<b>ZH</b>
ZU
ZL
ZY
ZQ
ZF
ZP
ZCU
AMJ
Misc.

## Compact and lightweight

The nozzle and the body, which have been made into a composite resin construction, are compact and lightweight. Nozzle diameter  $\varnothing 0.5$ ...28 g

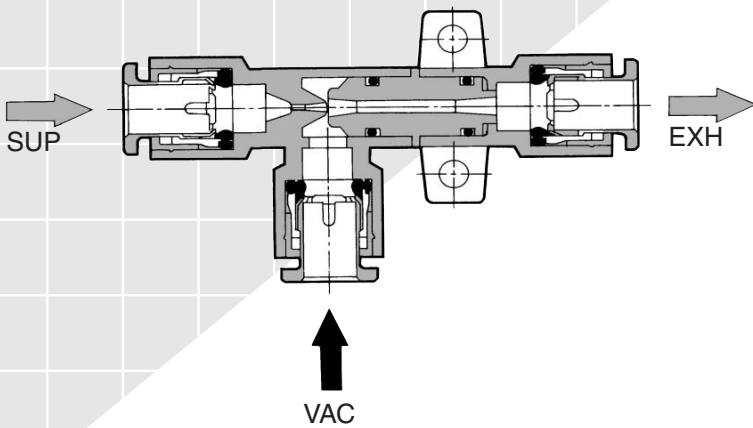

## Box type (Built-in silencer) Body ported

Two types are available in the series: the box type with a silencer exhaust, and the body ported type, with an individual exhaust.

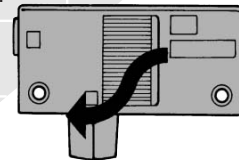

<Silencer exhaust>

## One-touch and screw-in connections can be combined.

To suit the operating conditions, port connections can be combined with a choice of One-touch and screw-in connections.

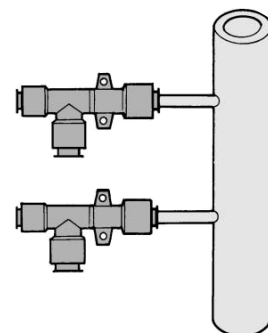

<Centralized exhaust>

## Body can be mounted and secured.

The body ported type is also provided with mounting holes for securing the body.

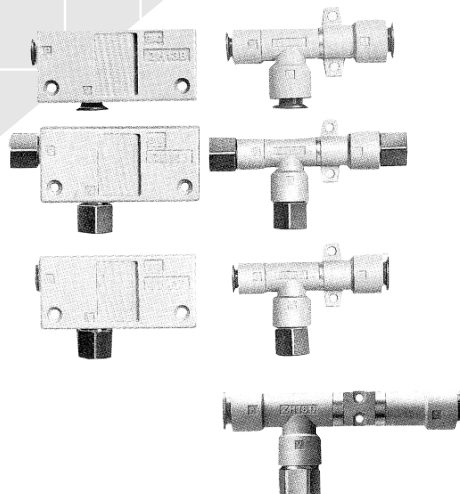
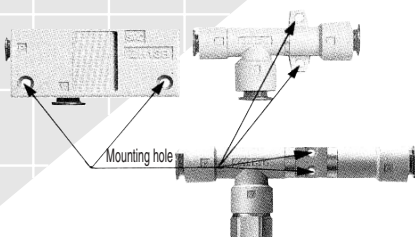

# Vacuum Ejector

## Box Type (Built-in Silencer)/Body Ported Type

# Series ZH

### How to Order

 **Note** Refer to "Table (1)" and "(2)" for the combination available for SUP, VAC and EXH port connection.

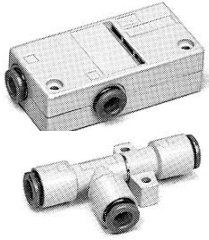

**Box type  
(Built-in silencer)**

ZH **07** B **S** - **06** - **06**

**Body ported type  
(Without silencer)**

ZH **07** D **S** - **01** - **01** - **01**

**Nozzle diameter**

05	0.5 mmø
07	0.7 mmø
10	1.0 mmø
13	1.3 mmø
15	1.5 mmø
18	1.8 mmø
20	2.0 mmø

**Maximum vacuum pressure**

S	-88 kPa
L	-48 kPa

**SUP. port size** <sup>Note)</sup>

Symbol	Size	Style
06	ø6	One-touch
08	ø8	One-touch
10	ø10	One-touch
12	ø12	One-touch
01	Rc 1/8	Screw-in
02	Rc 1/4	Screw-in
03	Rc 3/8	Screw-in

**EXH. port size** <sup>Note)</sup>

Symbol	Size	Style
06	ø6	One-touch
08	ø8	One-touch
10	ø10	One-touch
12	ø12	One-touch
16	ø16	One-touch
01	Rc 1/8	Screw-in
02	Rc 1/4	Screw-in
03	Rc 3/8	Screw-in
04	Rc 1/2	Screw-in

**VAC. port size** <sup>Note)</sup>

Symbol	Size	Style
06	ø6	One-touch
10	ø10	One-touch
12	ø12	One-touch
16	ø16	One-touch
01	Rc 1/8	Screw-in
02	Rc 1/4	Screw-in
03	Rc 3/8	Screw-in
04	Rc 1/2	Screw-in

**Table (1) Combination of Connection**

Body type		SUP	VAC	EXH
Box type (Built-in silencer)	1	One-touch	One-touch	—
	2	One-touch	Screw-in	—
	3	Screw-in	Screw-in	—
Body ported type (Without silencer)	1	One-touch	One-touch	One-touch
	2	One-touch	Screw-in	One-touch
	3	Screw-in	Screw-in	Screw-in

**Table (2) Port Size**

Model	Connection (One-touch/Screw-in)		
	SUP	VAC	EXH
ZH05B			
ZH07B	ø6/Rc 1/8	ø6/Rc 1/8	
ZH10B			—
ZH13B	ø8/Rc 1/8	ø10/Rc 1/4	
ZH05D	ø6/Rc 1/8	ø6/Rc 1/8	ø6/Rc 1/8
ZH07D			
ZH10D	ø6/Rc 1/8	ø6/Rc 1/8	ø8/Rc 1/8
ZH13D	ø8/Rc 1/8	ø10/Rc 1/4	ø10/Rc 1/4
ZH15D	ø10/Rc 1/4	ø12/Rc 3/8	ø12/Rc 3/8
ZH18D	ø12/Rc 3/8		
ZH20D	ø12/Rc 3/8	ø16/Rc 1/2	ø16/Rc 1/2



# Vacuum Ejector: Box Type (Built-in Silencer)/Body Ported Type **Series ZH**

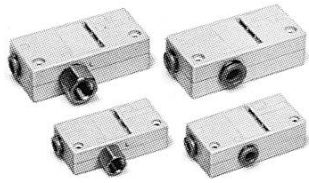

Box type: Type B

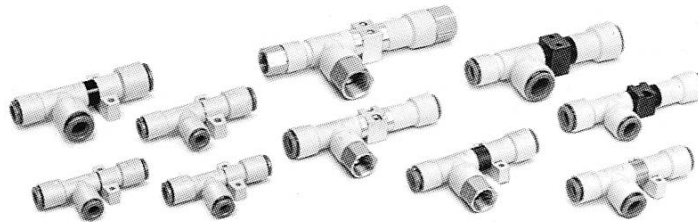

Body ported type: Type D

Ejector JIS Symbol

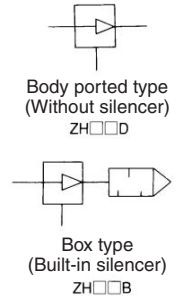

## Model

Model	Nozzle diameter (mm)	Body type	Max. vacuum pressure* (kPa)		Maximum suction flow rate (l/min (ANR))		Air consumption (l/min (ANR))	Connection (One-touch/Screw-in)			Weight (g)	
			Type S	Type L	Type S	Type L	Type S/Type L	SUP	VAC	EXH		
ZH05B□	0.5	Box type (Built-in silencer)	-88	-48	5	8	13	ø6/Rc 1/8	ø6/Rc 1/8	—	28	
ZH07B□	0.7				12	20	23					28
ZH10B□	1.0				24	34	46					
ZH13B□	1.3				40	70	78					66
ZH05D□	0.5	Body ported type (Without silencer)	-88	-48	5	8	13	ø6/Rc 1/8	ø6/Rc 1/8	ø6/Rc 1/8	11	
ZH07D□	0.7				12	20	23					12
ZH10D□	1.0				24	34	46					
ZH13D□	1.3				40	70	78					27
ZH15D□	1.5	Body ported type (Without silencer)	-88	-53	55	75	95	ø10/Rc 1/4	ø12/Rc 3/8	ø12/Rc 3/8	43	
ZH18D□	1.8				65	110	150					55
ZH20D□	2.0				85	135	185					

\* Supply pressure: 0.45 MPa.

## Construction

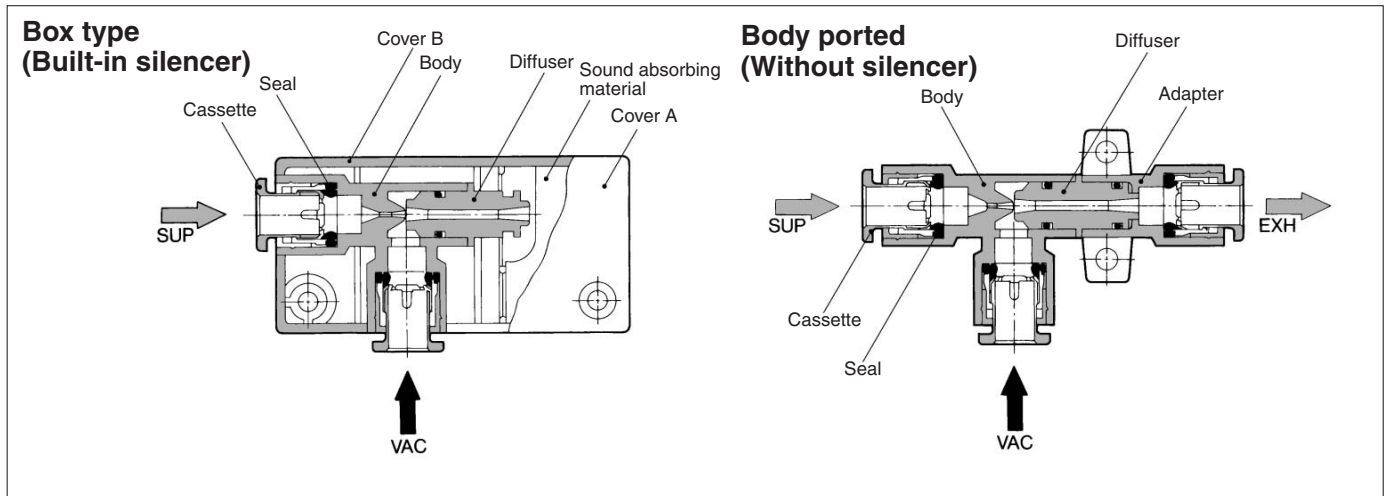

## ⚠ Precautions

Be sure to read before handling. Refer to pages 13-15-3 to 13-15-4 for Safety Instructions and Common Precautions on the products mentioned in this catalog, and refer to page 13-1-5 for Precautions on every series.

### ⚠ Caution

#### Mounting

Make sure that an excessive amount of load or moment is not applied to the ejector body due to pipe connections or installation.

#### Exhaust piping

On the ZH□□B□ models, keep exhaust ports open on at least one side. Make sure that the back pressure of the exhaust pipe on the ZH□□D□ models is 0.005 MPa or less. (Reference: Using tubing with an applicable diameter, its length must be 0.5 m or less.)  
(Port indication: P: supply port; V: vacuum port; E: exhaust port.)

#### Matching the ejector to the vacuum circuit

Refer to technical data on page 13-1-10 to 19 for precautions on the vacuum circuit.

- ZX
- ZR
- ZM
- ZH**
- ZU
- ZL
- ZY
- ZQ
- ZF
- ZP
- ZCU
- AMJ
- Misc.

# Series ZH

## Exhaust Characteristics/Flow Characteristics

The flow characteristics correspond to a supply pressure of 0.45 MPa.

### ZH05□S

Max. vacuum pressure: -88 kPa

#### Exhaust Characteristics

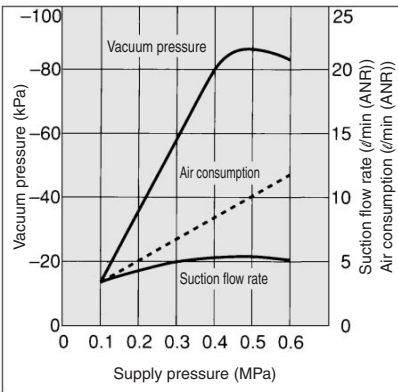

#### Flow Characteristics

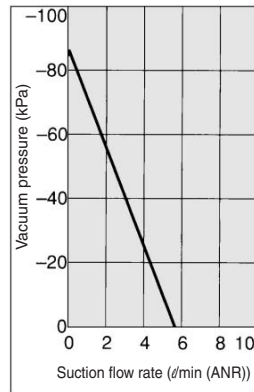

### ZH05□L

Max. vacuum pressure: -48 kPa

#### Exhaust Characteristics

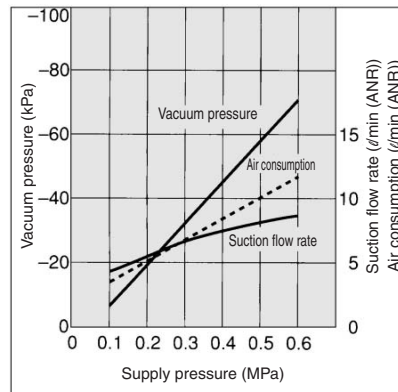

#### Flow Characteristics

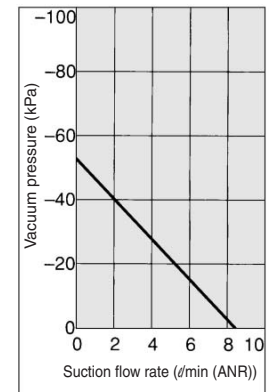

### ZH07□S

Max. vacuum pressure: -88 kPa

#### Exhaust Characteristics

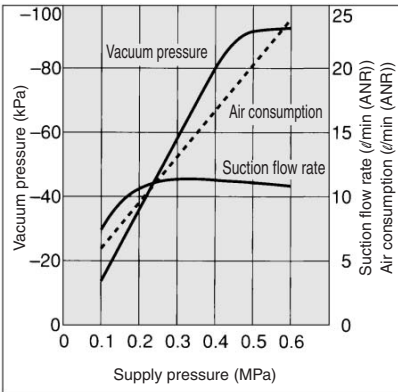

#### Flow Characteristics

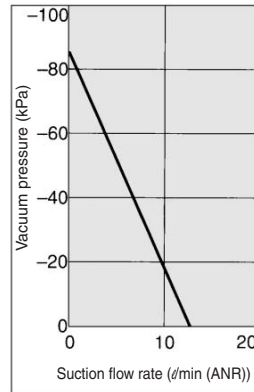

### ZH07□L

Max. vacuum pressure: -48 kPa

#### Exhaust Characteristics

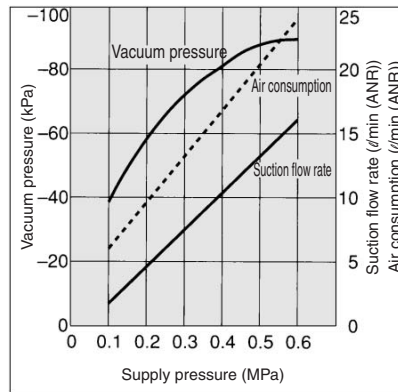

#### Flow Characteristics

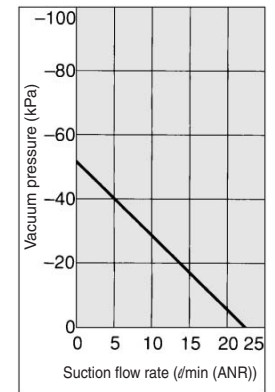

### ZH10□S

Max. vacuum pressure: -88 kPa

#### Exhaust Characteristics

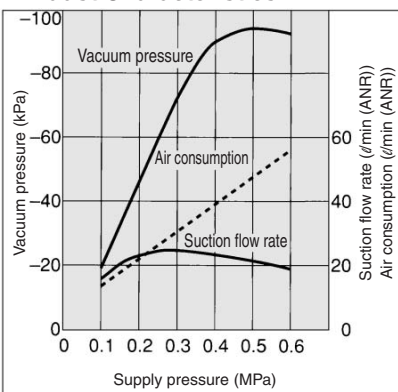

#### Flow Characteristics

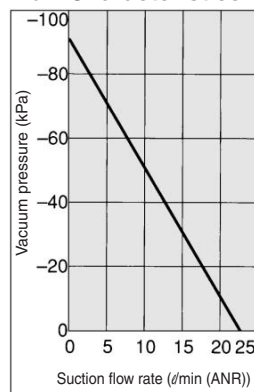

### ZH10□L

Max. vacuum pressure: -48 kPa

#### Exhaust Characteristics

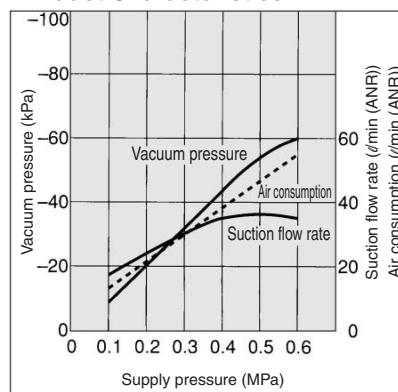

#### Flow Characteristics

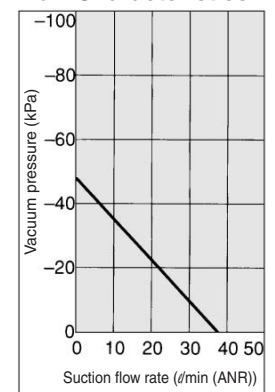

### ZH13□S

Max. vacuum pressure: -88 kPa

#### Exhaust Characteristics

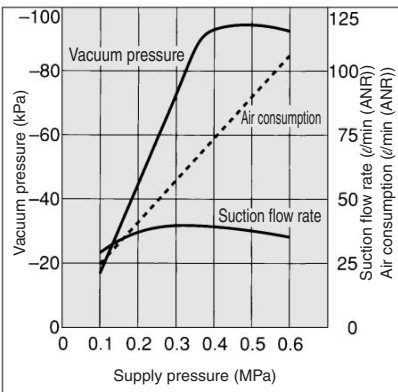

#### Flow Characteristics

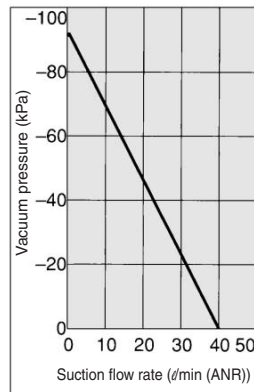

### ZH13□L

Max. vacuum pressure: -48 kPa

#### Exhaust Characteristics

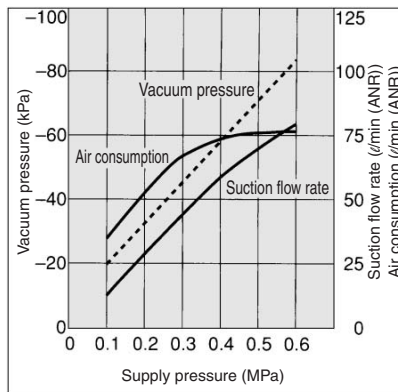

#### Flow Characteristics

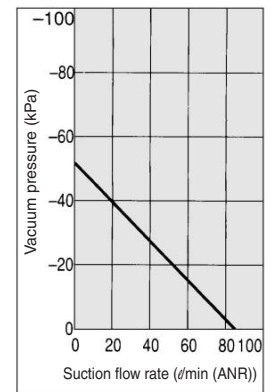



# Vacuum Ejector: Box Type (Built-in Silencer)/Body Ported Type **Series ZH**

## Exhaust Characteristics/Flow Characteristics

The flow characteristics correspond to a supply pressure of 0.45 MPa.

### ZH15□S

Max. vacuum pressure: -88 kPa

#### Exhaust Characteristics

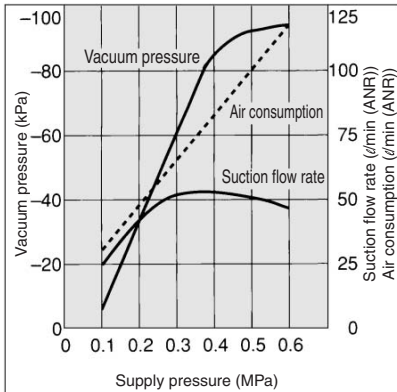

#### Flow Characteristics

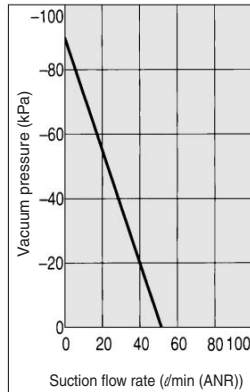

### ZH15□L

Max. vacuum pressure: -53 kPa

#### Exhaust Characteristics

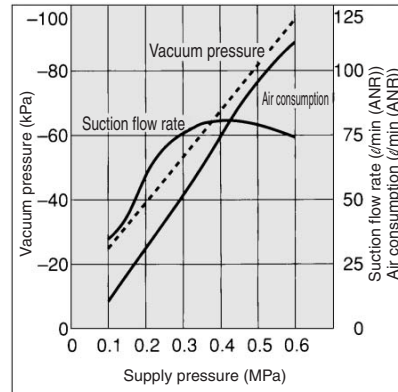

#### Flow Characteristics

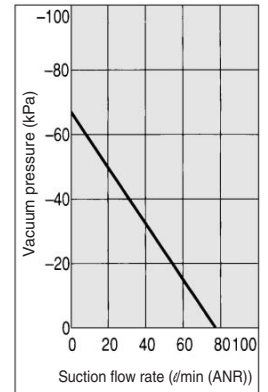

### ZH18□S

Max. vacuum pressure: -88 kPa

#### Exhaust Characteristics

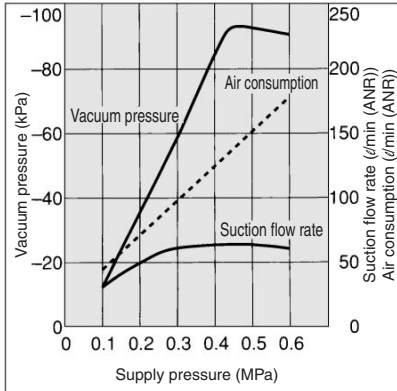

#### Flow Characteristics

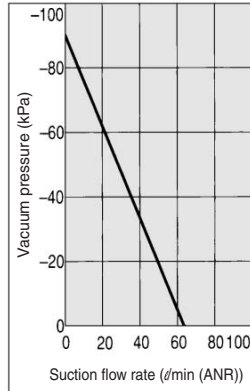

### ZH18□L

Max. vacuum pressure: -53 kPa

#### Exhaust Characteristics

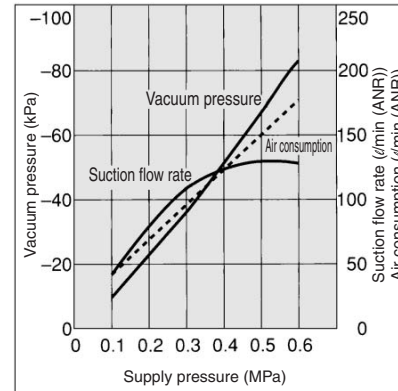

#### Flow Characteristics

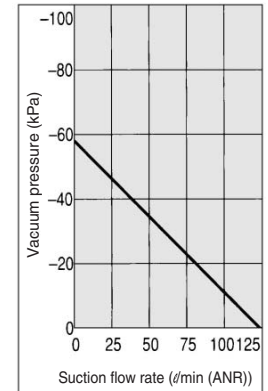

### ZH20□S

Max. vacuum pressure: -88 kPa

#### Exhaust Characteristics

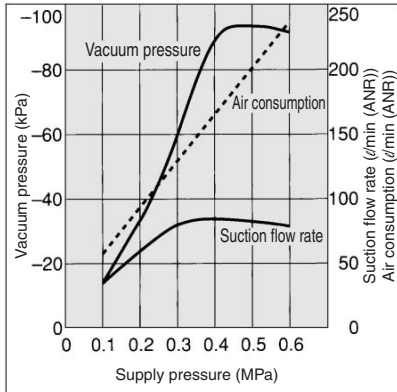

#### Flow Characteristics

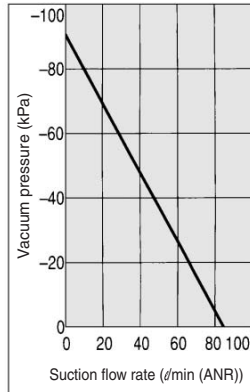

### ZH20□L

Max. vacuum pressure: -53 kPa

#### Exhaust Characteristics

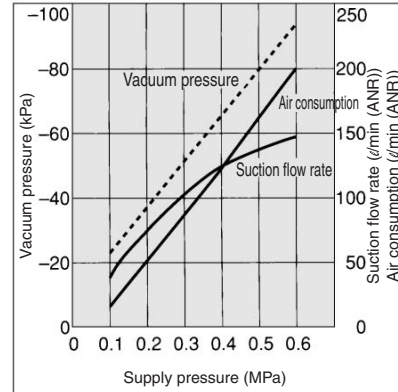

#### Flow Characteristics

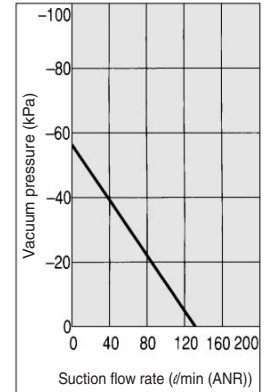

## How to Read Flow Characteristics Graph

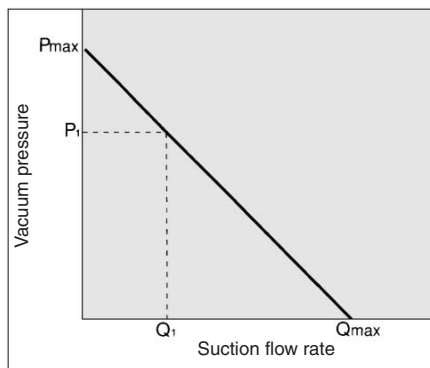

Flow characteristics are expressed in ejector vacuum pressure and suction flow. If suction flow rate changes, a change in vacuum pressure will also be expressed. Normally this relationship is expressed in ejector standard use.

In graph,  $P_{max}$  is max. vacuum pressure and  $Q_{max}$  is max. suction flow. The valves are specified according to catalog use. Changes in vacuum pressure are expressed in the order below.

1. When ejector suction port is covered and made airtight, suction flow becomes 0 and vacuum pressure is at maximum value ( $P_{max}$ ).
2. When suction port is opened gradually, air

can flow through, (air leakage), suction flow increases, but vacuum pressure decreases. (condition  $P_1$  and  $Q_1$ )

3. When suction port is opened further, suction flow moves to maximum value ( $Q_{max}$ ), but vacuum pressure is near 0. (atmospheric pressure).

When vacuum port (vacuum piping) has no leakage, vacuum pressure becomes maximum, and vacuum pressure decreases as leakage increases. When leakage value is the same as max. suction flow, vacuum pressure is near 0.

When ventirative or leaky work must be adsorbed, please note that vacuum pressure will not be high.

ZX

ZR

ZM

ZH

ZU

ZL

ZY

ZQ

ZF

ZP

ZCU

AMJ

Misc.

# Series ZH

## Box Type (Built-in silencer): ZH□B<sub>L</sub><sup>S</sup>-□-□

### One-touch connection

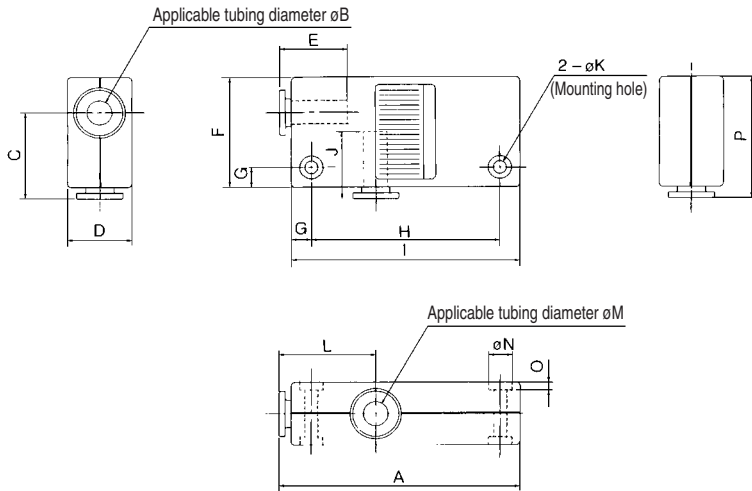

Model	A	φB	C	D	E	F	G	H
ZH05BS-06-06	60	6	22	16	12.8	28	5	47
ZH05BL-06-06	60	6	22	16	12.8	28	5	47
ZH07BS-06-06	60	6	22	16	12.8	28	5	47
ZH07BL-06-06	60	6	22	16	12.8	28	5	47
ZH10BS-06-06	63	6	23	18	12.8	29	5	50
ZH10BL-06-06	63	6	23	18	12.8	29	5	50
ZH13BS-08-10	78	8	27.5	23	13.7	35	7	61
ZH13BL-08-10	78	8	27.5	23	13.7	35	7	61

Model	I	J	φK	L	φM	φN	O	P
ZH05BS-06-06	57	12.8	3.2	24	6	5.8	2	31
ZH05BL-06-06	57	12.8	3.2	24	6	5.8	2	31
ZH07BS-06-06	57	12.8	3.2	24	6	5.8	2	31
ZH07BL-06-06	57	12.8	3.2	24	6	5.8	2	31
ZH10BS-06-06	60	12.8	3.2	26	6	5.8	2	32
ZH10BL-06-06	60	12.8	3.2	26	6	5.8	2	32
ZH13BS-08-10	75	15.3	4.2	28	10	7.5	3	38.5
ZH13BL-08-10	75	15.3	4.2	28	10	7.5	3	38.5

### One-touch and screw-in connection

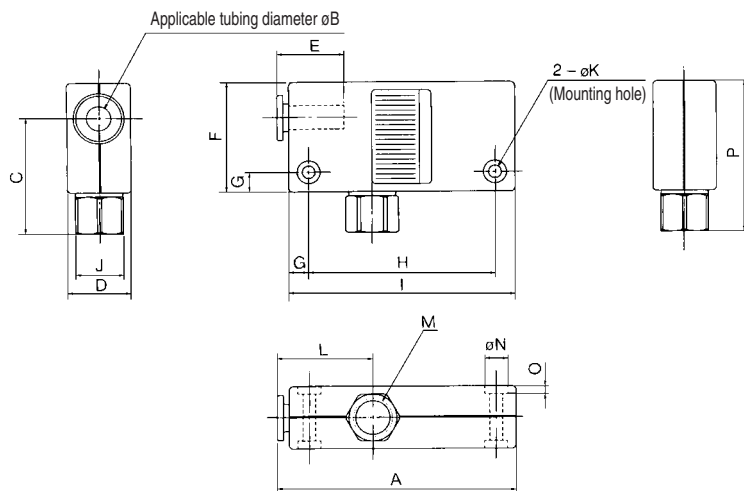

Model	A	φB	C	D	E	F	G	H
ZH05BS-06-01	60	6	29.5	16	12.8	28	5	47
ZH05BL-06-01	60	6	29.5	16	12.8	28	5	47
ZH07BS-06-01	60	6	29.5	16	12.8	28	5	47
ZH07BL-06-01	60	6	29.5	16	12.8	28	5	47
ZH10BS-06-01	63	6	30.5	18	12.8	29	5	50
ZH10BL-06-01	63	6	30.5	18	12.8	29	5	50
ZH13BS-08-02	78	8	39	23	13.7	35	7	61
ZH13BL-08-02	78	8	39	23	13.7	35	7	61

Model	I	J	φK	L	M	φN	O	P
ZH05BS-06-01	57	12	3.2	24	Rc1/8	5.8	2	38.5
ZH05BL-06-01	57	12	3.2	24	Rc1/8	5.8	2	38.5
ZH07BS-06-01	57	12	3.2	24	Rc1/8	5.8	2	38.5
ZH07BL-06-01	57	12	3.2	24	Rc1/8	5.8	2	38.5
ZH10BS-06-01	60	12	3.2	26	Rc1/8	5.8	2	39.5
ZH10BL-06-01	60	12	3.2	26	Rc1/8	5.8	2	39.5
ZH13BS-08-02	75	17	4.2	28	Rc1/4	7.5	3	50
ZH13BL-08-02	75	17	4.2	28	Rc1/4	7.5	3	50

### Screw-in connection

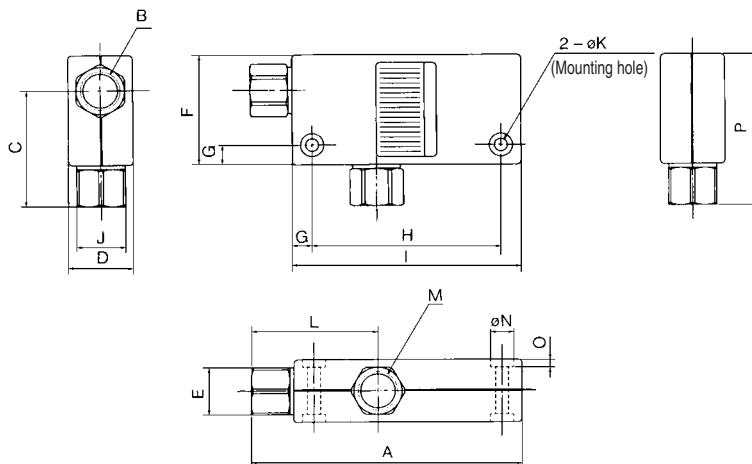

Model	A	B	C	D	E	F	G	H
ZH05BS-01-01	67.5	Rc1/8	29.5	16	12	28	5	47
ZH05BL-01-01	67.5	Rc1/8	29.5	16	12	28	5	47
ZH07BS-01-01	67.5	Rc1/8	29.5	16	12	28	5	47
ZH07BL-01-01	67.5	Rc1/8	29.5	16	12	28	5	47
ZH10BS-01-01	70.5	Rc1/8	30.5	18	12	29	5	50
ZH10BL-01-01	70.5	Rc1/8	30.5	18	12	29	5	50
ZH13BS-01-02	86.5	Rc1/8	39	23	14	35	7	61
ZH13BL-01-02	86.5	Rc1/8	39	23	14	35	7	61

Model	I	J	φK	L	M	φN	O	P
ZH05BS-01-01	57	12	3.2	31.5	Rc1/8	5.8	2	38.5
ZH05BL-01-01	57	12	3.2	31.5	Rc1/8	5.8	2	38.5
ZH07BS-01-01	57	12	3.2	31.5	Rc1/8	5.8	2	38.5
ZH07BL-01-01	57	12	3.2	31.5	Rc1/8	5.8	2	38.5
ZH10BS-01-01	60	12	3.2	33.5	Rc1/8	5.8	2	39.5
ZH10BL-01-01	60	12	3.2	33.5	Rc1/8	5.8	2	39.5
ZH13BS-01-02	75	17	4.2	36.5	Rc1/4	7.5	3	50
ZH13BL-01-02	75	17	4.2	36.5	Rc1/4	7.5	3	50

# Vacuum Ejector: Box Type (Built-in Silencer)/Body Ported Type **Series ZH**

## Body Ported Type (Without silencer): ZH05D<sup>S</sup><sub>L</sub>-□-□-□ to ZH15D<sup>S</sup><sub>L</sub>-□-□-□

### One-touch connection

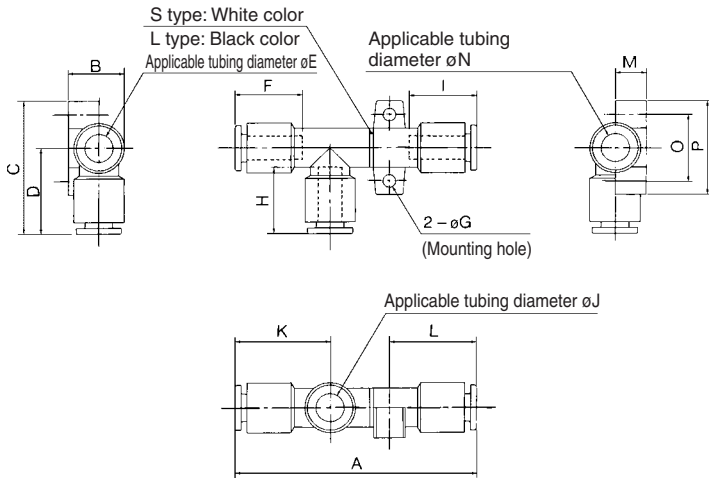

Model	A	B	C	D	øE	F	øG	H
ZH05DS-06-06-06	58.5	14.2	34	22	6	12.8	3.2	12.8
ZH05DL-06-06-06	58.5	14.2	34	22	6	12.8	3.2	12.8
ZH07DS-06-06-06	61	14.2	34	22	6	12.8	3.2	12.8
ZH07DL-06-06-06	61	14.2	34	22	6	12.8	3.2	12.8
ZH10DS-06-06-08	66	17.2	37	23	6	12.8	4.2	12.8
ZH10DL-06-06-08	70	17.2	37	23	6	12.8	4.2	12.8
ZH13DS-08-10-10	74.5	20	42.5	27.5	8	13.7	4.2	15.3
ZH13DL-08-10-10	79.5	20	42.5	27.5	8	13.7	4.2	15.3
ZH15DS-10-12-12	93.3	22.45	47	29.5	10	15.3	4.2	15.8
ZH15DL-10-12-12	93.3	22.45	47	29.5	10	15.3	4.2	15.8

Model	I	øJ	K	L	M	øN	O	P
ZH05DS-06-06-06	12.8	6	24	21	7.8	6	17	24
ZH05DL-06-06-06	12.8	6	24	21	7.8	6	17	24
ZH07DS-06-06-06	12.8	6	24	22	7.8	6	17	24
ZH07DL-06-06-06	12.8	6	24	22	7.8	6	17	24
ZH10DS-06-06-08	13.7	6	26	24.5	9.6	8	20	28
ZH10DL-06-06-08	13.7	6	26	24.5	9.6	8	20	28
ZH13DS-08-10-10	15.3	10	28	27	10.7	10	22	30
ZH13DL-08-10-10	15.3	10	28	27	10.7	10	22	30
ZH15DS-10-12-12	15.8	12	31.5	32.8	12	12	27	35
ZH15DL-10-12-12	15.8	12	31.5	32.8	12	12	27	35

### One-touch and screw-in connection

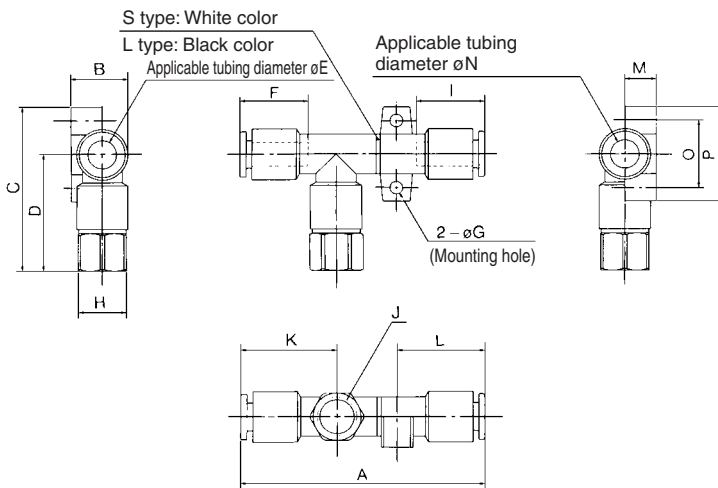

Model	A	B	C	D	øE	F	øG	H
ZH05DS-06-01-06	58.5	14.2	41.5	29.5	6	12.8	3.2	12
ZH05DL-06-01-06	58.5	14.2	41.5	29.5	6	12.8	3.2	12
ZH07DS-06-01-06	61	14.2	41.5	29.5	6	12.8	3.2	12
ZH07DL-06-01-06	61	14.2	41.5	29.5	6	12.8	3.2	12
ZH10DS-06-01-08	66	17.2	44.5	30.5	6	12.8	4.2	12
ZH10DL-06-01-08	70	17.2	44.5	30.5	6	12.8	4.2	12
ZH13DS-08-02-10	74.5	19.95	54	39	8	13.7	4.2	17
ZH13DL-08-02-10	79.5	19.95	54	39	8	13.7	4.2	17
ZH15DS-10-03-12	93.3	22.45	58.5	41	10	15.3	4.2	19
ZH15DL-10-03-12	93.3	22.45	58.5	41	10	15.3	4.2	19

Model	I	J	K	L	M	øN	O	P
ZH05DS-06-01-06	12.8	Rc <sup>1</sup> / <sub>8</sub>	24	21	7.8	6	17	24
ZH05DL-06-01-06	12.8	Rc <sup>1</sup> / <sub>8</sub>	24	21	7.8	6	17	24
ZH07DS-06-01-06	12.8	Rc <sup>1</sup> / <sub>8</sub>	24	22	7.8	6	17	24
ZH07DL-06-01-06	12.8	Rc <sup>1</sup> / <sub>8</sub>	24	22	7.8	6	17	24
ZH10DS-06-01-08	13.7	Rc <sup>1</sup> / <sub>8</sub>	26	24.5	9.6	8	20	28
ZH10DL-06-01-08	13.7	Rc <sup>1</sup> / <sub>8</sub>	26	24.5	9.6	8	20	28
ZH13DS-08-02-10	15.3	Rc <sup>1</sup> / <sub>4</sub>	28	27	10.7	10	22	30
ZH13DL-08-02-10	15.3	Rc <sup>1</sup> / <sub>4</sub>	28	27	10.7	10	22	30
ZH15DS-10-03-12	15.8	Rc <sup>3</sup> / <sub>8</sub>	31.5	32.8	12	12	27	35
ZH15DL-10-03-12	15.8	Rc <sup>3</sup> / <sub>8</sub>	31.5	32.8	12	12	27	35

### Screw-in connection

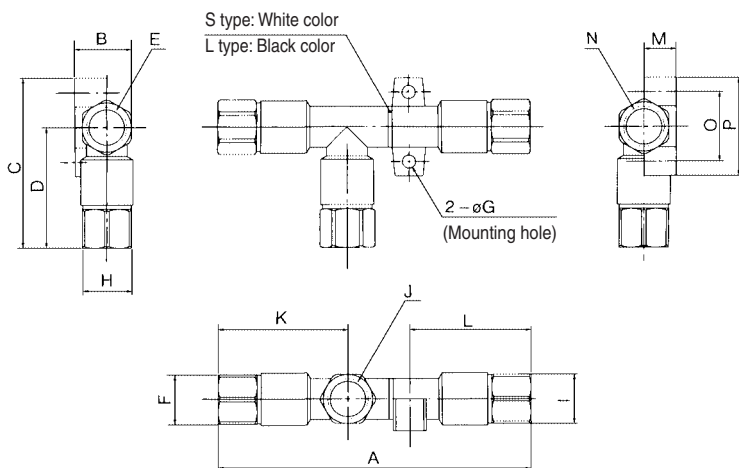

Model	A	B	C	D	E	F	øG	H
ZH05DS-01-01-01	73.5	14.2	41.5	29.5	Rc <sup>1</sup> / <sub>8</sub>	12	3.2	12
ZH05DL-01-01-01	73.5	14.2	41.5	29.5	Rc <sup>1</sup> / <sub>8</sub>	12	3.2	12
ZH07DS-01-01-01	76	14.2	41.5	29.5	Rc <sup>1</sup> / <sub>8</sub>	12	3.2	12
ZH07DL-01-01-01	76	14.2	41.5	29.5	Rc <sup>1</sup> / <sub>8</sub>	12	3.2	12
ZH10DS-01-01-01	82	17.2	44.5	30.5	Rc <sup>1</sup> / <sub>8</sub>	12	4.2	12
ZH10DL-01-01-01	86	17.2	44.5	30.5	Rc <sup>1</sup> / <sub>8</sub>	12	4.2	12
ZH13DS-01-02-02	94.5	19.95	54	39	Rc <sup>1</sup> / <sub>8</sub>	14	4.2	17
ZH13DL-01-02-02	99.5	19.95	54	39	Rc <sup>1</sup> / <sub>8</sub>	14	4.2	17
ZH15DS-02-03-03	116.5	22.45	58.5	41	Rc <sup>1</sup> / <sub>4</sub>	17	4.2	19
ZH15DL-02-03-03	116.5	22.45	58.5	41	Rc <sup>1</sup> / <sub>4</sub>	17	4.2	19

Model	I	J	K	L	M	N	O	P
ZH05DS-01-01-01	12	Rc <sup>1</sup> / <sub>8</sub>	31.5	28.5	7.8	Rc <sup>1</sup> / <sub>8</sub>	17	24
ZH05DL-01-01-01	12	Rc <sup>1</sup> / <sub>8</sub>	31.5	28.5	7.8	Rc <sup>1</sup> / <sub>8</sub>	17	24
ZH07DS-01-01-01	12	Rc <sup>1</sup> / <sub>8</sub>	31.5	29.5	7.8	Rc <sup>1</sup> / <sub>8</sub>	17	24
ZH07DL-01-01-01	12	Rc <sup>1</sup> / <sub>8</sub>	31.5	29.5	7.8	Rc <sup>1</sup> / <sub>8</sub>	17	24
ZH10DS-01-01-01	14	Rc <sup>1</sup> / <sub>8</sub>	33.5	33	9.6	Rc <sup>1</sup> / <sub>8</sub>	20	28
ZH10DL-01-01-01	14	Rc <sup>1</sup> / <sub>8</sub>	33.5	33	9.6	Rc <sup>1</sup> / <sub>8</sub>	20	28
ZH13DS-01-02-02	17	Rc <sup>1</sup> / <sub>4</sub>	36.5	38.5	10.7	Rc <sup>1</sup> / <sub>4</sub>	22	30
ZH13DL-01-02-02	17	Rc <sup>1</sup> / <sub>4</sub>	36.5	38.5	10.7	Rc <sup>1</sup> / <sub>4</sub>	22	30
ZH15DS-02-03-03	19	Rc <sup>3</sup> / <sub>8</sub>	43	44.5	12	Rc <sup>3</sup> / <sub>8</sub>	27	35
ZH15DL-02-03-03	19	Rc <sup>3</sup> / <sub>8</sub>	43	44.5	12	Rc <sup>3</sup> / <sub>8</sub>	27	35

- ZX
- ZR
- ZM
- ZH
- ZU
- ZL
- ZY
- ZQ
- ZF
- ZP
- ZCU
- AMJ
- Misc.

# Series ZH

## Body Ported Type (Without silencer): ZH18D<sub>L</sub><sup>S</sup>-□-□-□, ZH20D<sub>L</sub><sup>S</sup>-□-□-□

### One-touch connection

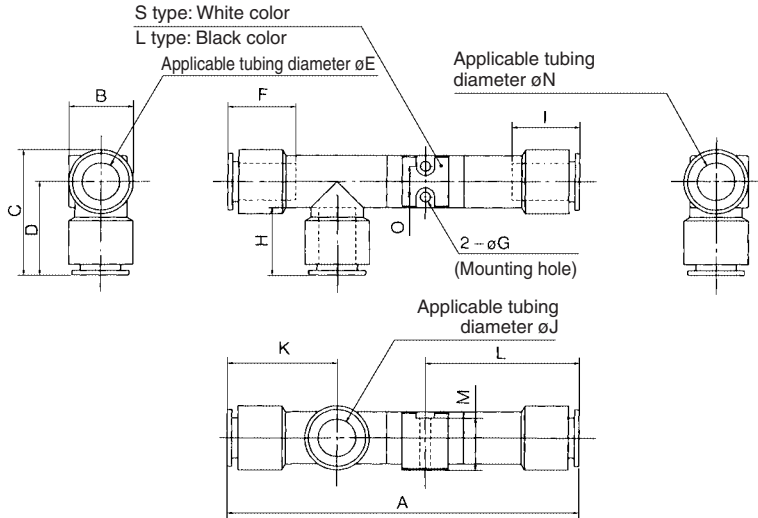

Model	A	B	C	D	øE	F	øG	H
ZH18DS-12-12-12	114	20.95	40.95	30.5	ø12	15.8	ø3.5	15.8
ZH18DL-12-12-12	114	20.95	40.95	30.5	ø12	15.8	ø3.5	15.8
ZH20DS-12-16-16	124.6	26.75	45.95	32.7	ø12	15.8	ø3.5	17.2
ZH20DL-12-16-16	124.6	26.75	45.95	32.7	ø12	15.8	ø3.5	17.2

Model	I	øJ	K	L	M	øN	O
ZH18DS-12-12-12	15.8	ø12	35.5	50	17	ø12	10
ZH18DL-12-12-12	15.8	ø12	35.5	50	17	ø12	10
ZH20DS-12-16-16	17.2	ø16	38.5	54.3	21.7	ø16	12
ZH20DL-12-16-16	17.2	ø16	38.5	54.3	21.7	ø16	12

### One-touch and screw-in connection

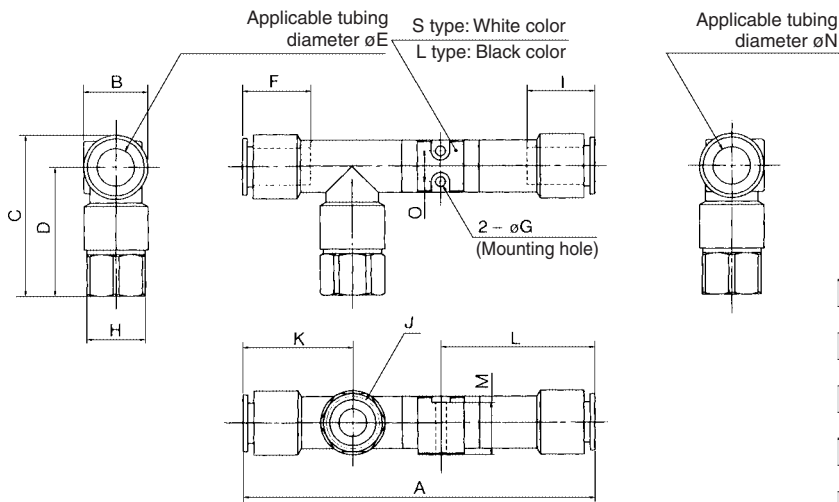

Model	A	B	C	D	øE	F	øG	H
ZH18DS-12-03-12	110	20.95	52.45	42	ø12	15.8	ø3.5	19
ZH18DL-12-03-12	110	20.95	52.45	42	ø12	15.8	ø3.5	19
ZH20DS-12-04-16	124.6	26.75	60.95	47.7	ø12	15.8	ø3.5	24
ZH20DL-12-04-16	124.6	26.75	60.95	47.7	ø12	15.8	ø3.5	24

Model	I	J	K	L	M	øN	O
ZH18DS-12-03-12	15.8	Rc <sup>3</sup> / <sub>8</sub>	35.5	50	17	ø12	10
ZH18DL-12-03-12	15.8	Rc <sup>3</sup> / <sub>8</sub>	35.5	50	17	ø12	10
ZH20DS-12-04-16	17.2	Rc <sup>1</sup> / <sub>2</sub>	38.5	54.3	21.7	ø16	12
ZH20DL-12-04-16	17.2	Rc <sup>1</sup> / <sub>2</sub>	38.5	54.3	21.7	ø16	12

### Screw-in connection

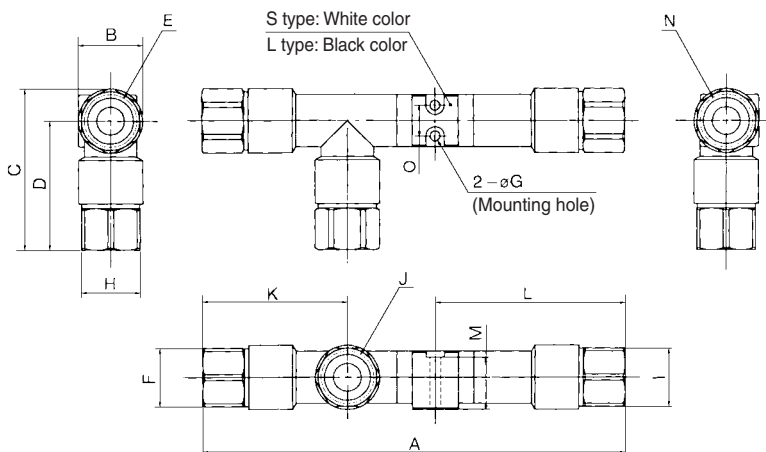

Model	A	B	C	D	E	F	øG	H
ZH18DS-03-03-03	133	20.95	52.45	42	Rc <sup>3</sup> / <sub>8</sub>	19	ø3.5	19
ZH18DL-03-03-03	133	20.95	52.45	42	Rc <sup>3</sup> / <sub>8</sub>	19	ø3.5	19
ZH20DS-03-04-04	151.1	26.75	60.95	47.7	Rc <sup>3</sup> / <sub>8</sub>	19	ø3.5	24
ZH20DL-03-04-04	151.1	26.75	60.95	47.7	Rc <sup>3</sup> / <sub>8</sub>	19	ø3.5	24

Model	I	J	K	L	M	N	O
ZH18DS-03-03-03	19	Rc <sup>3</sup> / <sub>8</sub>	47	57.5	17	Rc <sup>3</sup> / <sub>8</sub>	10
ZH18DL-03-03-03	19	Rc <sup>3</sup> / <sub>8</sub>	47	57.5	17	Rc <sup>3</sup> / <sub>8</sub>	10
ZH20DS-03-04-04	24	Rc <sup>1</sup> / <sub>2</sub>	50	69.3	22	Rc <sup>1</sup> / <sub>2</sub>	12
ZH20DL-03-04-04	24	Rc <sup>1</sup> / <sub>2</sub>	50	69.3	22	Rc <sup>1</sup> / <sub>2</sub>	12

**Example of Application Circuit**

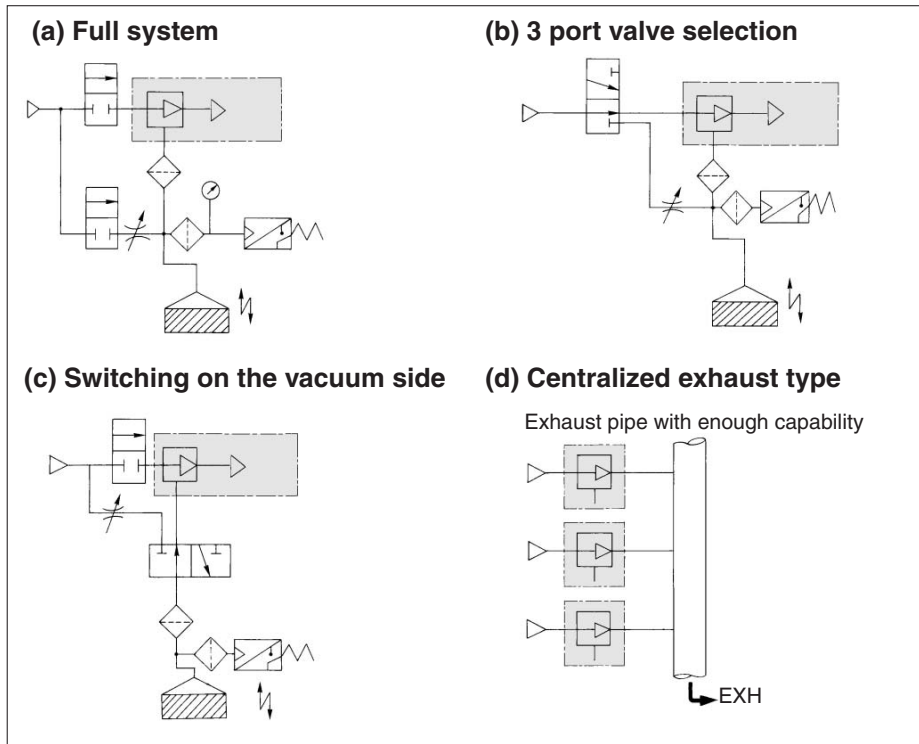
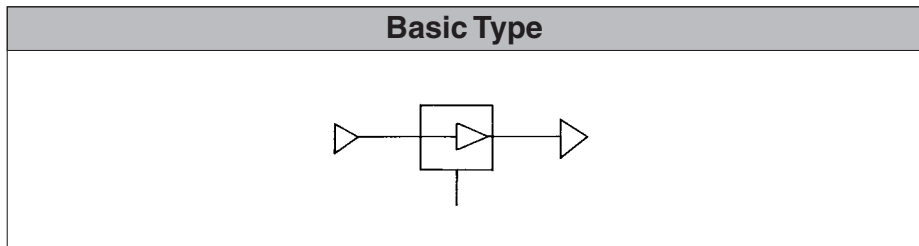

Diagrams (a) to (d) show the combination with peripherals.

**⚠ Caution**

**Handling of application circuits**

**1. Countermeasures for power outages**  
Select a supply valve for the ejector that is normally open or one that is equipped with a self-holding function.

**2. Using a small-diameter picking nozzle**  
For picking electronic parts or small precision parts, if the picking nozzle is approximately  $\phi 1$  mm in diameter, the vacuum remains high by being restricted by the nozzle. As a result, it will not be possible to verify it with the vacuum switch. In such a case, it is necessary to use an ejector that is suited to the nozzle and to select a vacuum switch with a favorable hysteresis and precision.

**3. Considerable leakage from the suction surface**

If a workpiece is made of porous material or if there is air leakage from the area between the pad and the workpiece, use a nozzle with a large diameter and a large suction flow volume.

If the amount of leakage is known based on the effective sectional area of the side with the leakage, the vacuum pressure can be estimated in accordance with the ejector's flow volume characteristics.

**4. Suction filter**

To protect the ejectors and valves from dust, the use of a suction filter (Series ZFA, ZFB) is recommended.

**5. Use of a vacuum switch**

It is recommended that verification be made with a vacuum switch as much as possible.

**6. Vacuum release valve**

To serve as a vacuum release valve, use a 2 port or 3 port valve. As for the performance of the valve, select a valve for a low vacuum. In addition, add a needle valve that can regulate the flow volume of the vacuum releasing air. Use the atmospheric pressure or a positive pressure for the vacuum releasing pressure.

ZX

ZR

ZM

ZH

ZU

ZL

ZY

ZQ

ZF

ZP

ZCU

AMJ

Misc.







# Safety Instructions

These safety instructions are intended to prevent a hazardous situation and/or equipment damage. These instructions indicate the level of potential hazard by labels of "Caution", "Warning" or "Danger". To ensure safety, be sure to observe ISO 4414 <sup>Note 1)</sup>, JIS B 8370 <sup>Note 2)</sup> and other safety practices.

 **Caution** : Operator error could result in injury or equipment damage.

 **Warning** : Operator error could result in serious injury or loss of life.

 **Danger** : In extreme conditions, there is a possible result of serious injury or loss of life.

Note 1) ISO 4414: Pneumatic fluid power--General rules relating to systems.

Note 2) JIS B 8370: General Rules for Pneumatic Equipment

## Warning

### **1. The compatibility of pneumatic equipment is the responsibility of the person who designs the pneumatic system or decides its specifications.**

Since the products specified here are used in various operating conditions, their compatibility for the specific pneumatic system must be based on specifications or after analysis and/or tests to meet your specific requirements. The expected performance and safety assurance will be the responsibility of the person who has determined the compatibility of the system. This person should continuously review the suitability of all items specified, referring to the latest catalog information with a view to giving due consideration to any possibility of equipment failure when configuring a system.

### **2. Only trained personnel should operate pneumatically operated machinery and equipment.**

Compressed air can be dangerous if an operator is unfamiliar with it. Assembly, handling or repair of pneumatic systems should be performed by trained and experienced operators.

### **3. Do not service machinery/equipment or attempt to remove components until safety is confirmed.**

1. Inspection and maintenance of machinery/equipment should only be performed once measures to prevent falling or runaway of the driver objects have been confirmed.
2. When equipment is to be removed, confirm the safety process as mentioned above. Cut the supply pressure for this equipment and exhaust all residual compressed air in the system.
3. Before machinery/equipment is restarted, take measures to prevent shooting-out of cylinder piston rod, etc.

### **4. Contact SMC if the product is to be used in any of the following conditions:**

1. Conditions and environments beyond the given specifications, or if product is used outdoors.
2. Installation on equipment in conjunction with atomic energy, railway, air navigation, vehicles, medical equipment, food and beverages, recreation equipment, emergency stop circuits, clutch and brake circuits in press applications, or safety equipment.
3. An application which has the possibility of having negative effects on people, property, or animals, requiring special safety analysis.



# Common Precautions

Be sure to read before handling.

For detailed precautions on every series, refer to main text.

## Selection

### Warning

#### 1. Confirm the specifications.

Products represented in this catalog are designed for use in compressed air applications only (including vacuum), unless otherwise indicated.

Do not use the product outside their design parameters.

Please contact SMC when using the products in applications other than compressed air (including vacuum).

## Mounting

### Warning

#### 1. Instruction manual

Install the products and operate them only after reading the instruction manual carefully and understanding its contents. Also keep the manual where it can be referred to as necessary.

#### 2. Securing the space for maintenance

When installing the products, please allow access for maintenance.

#### 3. Tightening torque

When installing the products, please follow the listed torque specifications.

## Piping

### Caution

#### 1. Before piping

Make sure that all debris, cutting oil, dust, etc., are removed from the piping.

#### 2. Wrapping of pipe tape

When screwing piping or fittings into ports, ensure that chips from the pipe threads or sealing material do not get inside the piping. Also, when the pipe tape is used, leave 1.5 to 2 thread ridges exposed at the end of the threads.

## Air Supply

### Warning

#### 1. Operating fluid

Please consult with SMC when using the product in applications other than compressed air (including vacuum).

Regarding products for general fluid, please ask SMC about applicable fluids.

#### 2. Install an air dryer, aftercooler, etc.

Excessive condensate in a compressed air system may cause valves and other pneumatic equipment to malfunction.

Installation of an air dryer, after cooler etc. is recommended.

#### 3. Drain flushing

If condensate in the drain bowl is not emptied on a regular basis, the bowl will over flow and allow the condensate to enter the compressed air lines.

If the drain bowl is difficult to check and remove, it is recommended that a drain bowl with the auto-drain option be installed.

For compressed air quality, refer to "Air Preparation Equipment" catalog.

#### 4. Use clean air

If the compressed air supply is contaminated with chemicals, synthetic materials, corrosive gas, etc., it may lead to break down or malfunction.

## Operating Environment

### Warning

1. Do not use in environments where the product is directly exposed to corrosive gases, chemicals, salt water, water or steam.

2. Do not expose the product to direct sunlight for an extended period of time.

3. Do not use in a place subject to heavy vibrations and/or shocks.

4. Do not mount the product in locations where it is exposed to radiant heat.

## Maintenance

### Warning

1. Maintenance procedures are outlined in the operation manual.

Not following proper procedures could cause the product to malfunction and could lead to damage to the equipment or machine.

#### 2. Maintenance work

If handled improperly, compressed air can be dangerous.

Assembly, handling and repair of pneumatic systems should be performed by qualified personnel only.

#### 3. Drain flushing

Remove drainage from air filters regularly. (Refer to the specifications.)

#### 4. Shut-down before maintenance

Before attempting any kind of maintenance make sure the supply pressure is shut of and all residual air pressure is released from the system to be worked on.

#### 5. Start-up after maintenance and inspection

Apply operating pressure and power to the equipment and check for proper operation and possible air leaks. If operation is abnormal, please verify product set-up parameters.

#### 6. Do not make any modifications to be product.

Do not take the product apart.



# Quality Assurance Information (ISO 9001, ISO 14001)

## Reliable quality of products in the global market

To enable our customers throughout the world to use our products with even greater confidence, SMC has obtained certification for international standards “ISO 9001” and “ISO 14001”, and created a complete structure for quality assurance and environmental controls. SMC products pursue to meet its customers’ expectations while also considering company’s contribution in society.

### Quality management system ISO 9001

This is an international standard for quality control and quality assurance. SMC has obtained a large number of certifications in Japan and overseas, providing assurance to our customers throughout the world.



### Environmental management system ISO 14001

This is an international standard related to environmental management systems and environmental inspections. While promoting environmentally friendly automation technology, SMC is also making diligent efforts to preserve the environment.



## SMC’s quality control system



### Quality policies

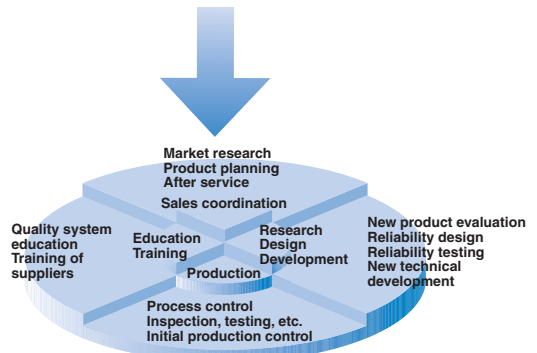

### Quality control activities

# SMC Product Conforming to Inter

SMC products complying with EN/ISO, CSA/UL standards are supporting



The CE mark indicates that machines and components meet essential requirements of all the EC Directives applied.

It has been obligatory to apply CE marks indicating conformity with EC Directives when machines and components are exported to the member Nations of the EU.

Once "A manufacturer himself" declares a product to be safe by means of CE marking (declaration of conformity by manufacturer), free distribution inside the member Nations of the EU is permissible.

## ■ CE Mark

SMC provides CE marking to products to which EMC and Low Voltage Directives have been applied, in accordance with CETOP (European hydraulics and pneumatics committee) guide lines.

## ■ As of February 1998, the following 18 countries will be obliged to conform to CE mark legislation

Iceland, Ireland, United Kingdom, Italy, Austria, Netherlands, Greece, Liechtenstein, Sweden, Spain, Denmark, Germany, Norway, Finland, France, Belgium, Portugal, Luxembourg

## ■ EC Directives and Pneumatic Components

### • Machinery Directive

The Machinery Directive contains essential health and safety requirements for machinery, as applied to industrial machines e.g. machine tools, injection molding machines and automatic machines. Pneumatic equipment is not specified in Machinery Directive. However, the use of SMC products that are certified as conforming to EN Standards, allows customers to simplify preparation work of the Technical Construction File required for a Declaration of Conformity.

### • Electromagnetic Compatibility (EMC) Directive

The EMC Directive specifies electromagnetic compatibility. Equipment which may generate electromagnetic interference or whose function may be compromised by electromagnetic interference is required to be immune to electromagnetic affects (EMS/immunity) without emitting excessive electromagnetic affects (EMI/emission).

### • Low Voltage Directive

This directive is applied to products, which operate above 50 VAC to 1000 VAC and 75 VDC to 1500 VDC operating voltage, and require electrical safety measures to be introduced.

### • Simple Pressure Vessels Directive

This directive is applied to welded vessels whose maximum operating pressure (PS) and volume of vessel (V) exceed 50 bar/L. Such vessels require EC type examination and then CE marking.

# national Standards

you to comply with EC directives and CSA/UL standards.



## ■ CSA Standards & UL Standards

UL and CSA standards have been applied in North America (U.S.A. and Canada) symbolizing safety of electric products, and are defined to mainly prevent danger from electric shock or fire, resulting from trouble with electric products. Both UL and CSA standards are acknowledged in North America as the first class certifying body. They have a long experience and ability for issuing product safety certificate. Products approved by CSA or UL standards are accepted in most states and governments beyond question.

Since CSA is a test certifying body as the National Recognized Testing Laboratory (NRTL) within the jurisdiction of Occupational Safety and Health Administration (OSHA), SMC was tested for compliance with CSA Standards and UL Standards at the same time and was approved for compliance with the two Standards. The above CSA NRTL/C logo is described on a product label in order to indicate that the product is approved by CSA and UL Standards.

## ■ TSSA (MCCR) Registration Products

TSSA is the regulation in Ontario State, Canada. The products that the operating pressure is more than 5 psi (0.03 MPa) and the piping size is bigger than 1 inch. fall into the scope of TSSA regulation.

## Products conforming to CE Standard



With CE symbol for simple visual recognition

In this catalog each accredited product series is indicated with a CE mark symbol. However, in some cases, every available models may not meet CE compliance. Please visit our web site for the latest selection of available models with CE mark.

<http://www.smcworld.com>

# SMC's Global Service Network

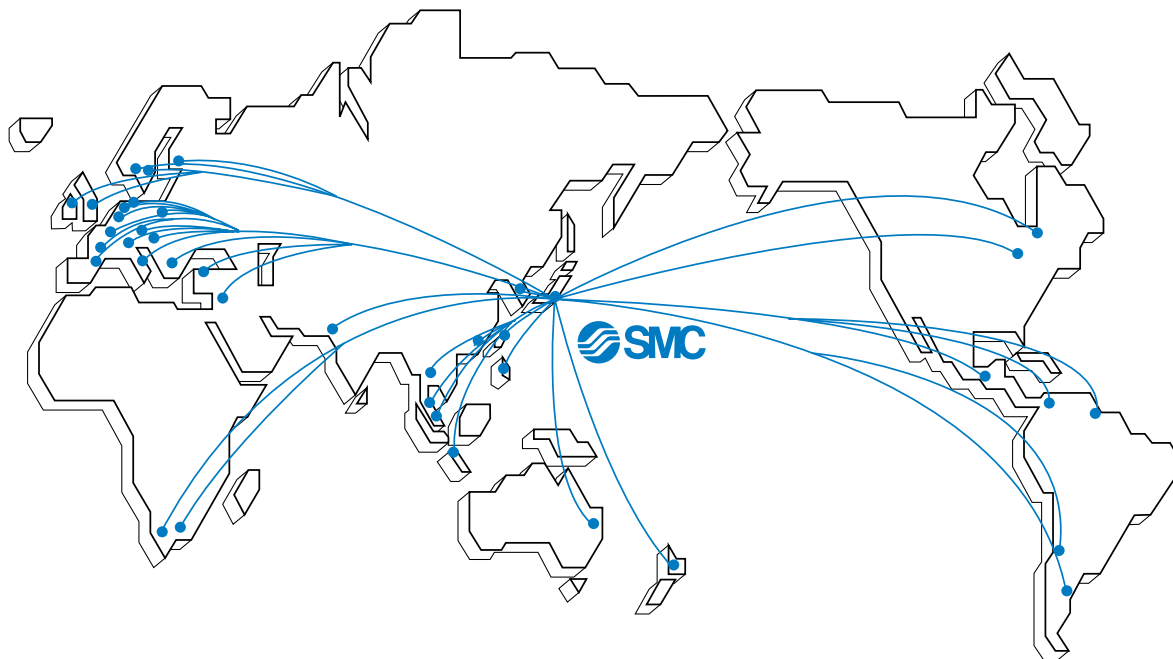

## America

### U.S.A. **SMC Corporation of America**

3011 North Franklin Road Indianapolis, IN 46226, U.S.A.  
TEL: 317-899-4440 FAX: 317-899-3102

### CANADA **SMC Pneumatics (Canada) Ltd.**

6768 Financial Drive Mississauga, Ontario, L5N 7J6 Canada  
TEL: 905-812-0400 FAX: 905-812-8686

### MEXICO **SMC Corporation (Mexico), S.A. DE C.V.**

Carr. Silao-Trejo K.M. 2.5 S/N, Predio San Jose del Duranzo  
C.P. 36100, Silao, Gto., Mexico  
TEL: 472-72-2-55-00 FAX: 472-72-2-59-44/2-59-46

### CHILE **SMC Pneumatics (Chile) S.A.**

Av. La Montaña 1,115 km. 16.5 P. Norte Parque  
Industrial Valle Grande, Lampa Santiago, Chile  
TEL: 02-270-8600 FAX: 02-270-8601

### ARGENTINA **SMC Argentina S.A.**

Teodoro Garcia 3860 (1427) Buenos Aires, Argentina  
TEL: 011-4555-5762 FAX: 011-4555-5762

### BOLIVIA **SMC Pneumatics Bolivia S.R.L.**

Avenida Beni Numero 4665  
Santa Cruz de la Sierra-Casilla de Correo 2281, Bolivia  
TEL: 591-3-3428383 FAX: 591-3-3449900

### VENEZUELA **SMC Neumatica Venezuela S.A.**

Apartado 40152, Avenida Nueva Granada, Edificio Wanlac,  
Local 5, Caracas 1040-A, Venezuela  
TEL: 2-632-1310 FAX: 2-632-3871

### PERU (Distributor) **IMPECO Automatizacion Industrial S.A.**

AV. Canevaro 752, Lince, Lima, Peru  
TEL: 1-471-6002 FAX: 1-471-0935

### URUGUAY (Distributor) **BAKO S.A.**

Galicia 1650 esq. Gaboto C.P. 11200, Montevideo, Uruguay  
TEL: 2-401-6603 FAX: 2-409-4306

### BRAZIL **SMC Pneumaticos Do Brasil Ltda.**

Rua. Dra. Maria Fidelis, nr. 130, Jardim Piraporinha-Diadema-S.P.  
CEP: 09950-350, Brasil  
TEL: 11-4051-1177 FAX: 11-4071-6636

### COLOMBIA (Distributor) **Airmatic Ltda.**

Calle 18 69-05 Apart. Aereo 081045 Santa Fe de Bogotá, Colombia  
TEL: 1-424-9240 FAX: 1-424-9260

## Europe

### U.K. **SMC Pneumatics (U.K.) Ltd.**

Vincent Avenue, Crownhill, Milton Keynes, MK8 0AN, Buckinghamshire, U.K.  
TEL: 01908-563888 FAX: 01908-561185

### GERMANY **SMC Pneumatik GmbH**

Boschring 13-15 D-63329 Egelsbach, Germany  
TEL: 06103-4020 FAX: 06103-402139

### ITALY **SMC Italia S.p.A.**

Via Garibaldi 62 I-20061 Carugate Milano, Italy  
TEL: 02-9271365 FAX: 02-9271365

### FRANCE **SMC Pneumatique S.A.**

1 Boulevard de Strasbourg, Parc Gustave Eiffel, Bussy Saint Georges, F-77600  
Marne La Vallee Cedex 3 France  
TEL: 01-64-76-10-00 FAX: 01-64-76-10-10

### SWEDEN **SMC Pneumatics Sweden AB**

Ekhagsvägen 29-31, S-141 05 Huddinge, Sweden  
TEL: 08-603-07-00 FAX: 08-603-07-10

### SWITZERLAND **SMC Pneumatik AG**

Dorfstrasse 7, Postfach 117, CH-8484 Weisslingen, Switzerland  
TEL: 052-396-3131 FAX: 052-396-3191

### AUSTRIA **SMC Pneumatik GmbH (Austria)**

Girakstrasse 8, A-2100 Korneuburg, Austria  
TEL: 0-2262-6228-0 FAX: 0-2262-62285

### SPAIN **SMC España, S.A.**

Zuazobidea 14 Pol. Ind. Júndiz 01015 Vitoria, Spain  
TEL: 945-184-100 FAX: 945-184-510

### IRELAND **SMC Pneumatics (Ireland) Ltd.**

2002 Citywest Business Campus, Naas Road, Saggart, Co. Dublin, Ireland  
TEL: 01-403-9000 FAX: 01-466-0385

### NETHERLANDS (Associated company) **SMC Pneumatics BV**

De Ruyterkade 120, NL-1011 AB Amsterdam, Netherlands  
TEL: 020-5318888 FAX: 020-5318880

### GREECE (Distributor) **S.Parianopoulos S.A.**

7, Konstantinoupoleos Street 11855 Athens, Greece  
TEL: 01-3426076 FAX: 01-3455578

### DENMARK **SMC Pneumatik A/S**

Knudsminde 4 B DK-8300  
Odder, Denmark  
TEL: 70252900 FAX: 70252901

## Europe

**FINLAND SMC Pneumatics Finland OY**

PL72, Tiistiniityntie 4, SF-02231 ESP00, Finland  
TEL: 09-8595-80 FAX: 09-8595-8595

**NORWAY SMC Pneumatics Norway A/S**

Vollsvæien 13C, Granfoss Næringspark N-1366 LYSAKER, Norway  
TEL: 67-12-90-20 FAX: 67-12-90-21

**BELGIUM (Distributor) SMC Pneumatics N.V./S.A.**

Nijverheidsstraat 20 B-2160 Wommelgem Belgium  
TEL: 03-355-1464 FAX: 03-355-1466

**POLAND SMC Industrial Automation Polska Sp.z.o.o.**

ul. Konstruktorska 11A, PL-02-673 Warszawa, Poland  
TEL: 022-548-5085 FAX: 022-548-5087

**TURKEY (Distributor) Entek Pnömatik San.ve Tic. Ltd. Sti**

Perpa Tic. Merkezi Kat:11 No.1625 80270 Okmeydani Istanbul, Türkiye  
TEL: 0212-221-1512 FAX: 0212-221-1519

**RUSSIA SMC Pneumatik LLC.**

36/40 Sredny prospect V.O. St. Petersburg 199004, Russia  
TEL: 812-118-5445 FAX: 812-118-5449

**CZECH SMC Industrial Automation CZ s.r.o.**

Hudcova 78a, CZ-61200 Brno, Czech Republic  
TEL: 05-4121-8034 FAX: 05-4121-8034

**HUNGARY SMC Hungary Ipari Automatizálási kft.**

Budafoki ut 107-113 1117 Budapest  
TEL: 01-371-1343 FAX: 01-371-1344

**ROMANIA SMC Romania S.r.l.**

Str. Frunzei, Nr. 29, Sector 2, Bucharest, Romania  
TEL: 01-3205111 FAX: 01-3261489

**SLOVAKIA SMC Priemyselná automatizácia, s.r.o.**

Nova 3, SK-83103 Bratislava  
TEL: 02-4445-6725 FAX: 02-4445-6028

**SLOVENIA SMC Industrijska Avtomatila d.o.o.**

Grajski trg 15, SLO- 8360 Zuzemberk, Slovenia  
TEL: 07388-5240 FAX: 07388-5249

**LATVIA SMC Pneumatics Latvia SIA**

Šmerļa ielā 1-705, Rīga LV-1006  
TEL: 777 94 74 FAX: 777 94 75

**SOUTH AFRICA (Distributor) Hyflo Southern Africa (Pty.) Ltd.**

P.O.Box 240 Paardeneiland 7420 South Africa  
TEL: 021-511-7021 FAX: 021-511-4456

**EGYPT (Distributor) Saadani Trading & Ind. Services**

15 Sebaai Street, Miami 21411 Alexandria, Egypt  
TEL: 3-548-50-34 FAX: 3-548-50-34

## Oceania/Asia

**AUSTRALIA SMC Pneumatics (Australia) Pty.Ltd.**

14-18 Hudson Avenue Castle Hill NSW 2154, Australia  
TEL: 02-9354-8222 FAX: 02-9894-5719

**NEW ZEALAND SMC Pneumatics (New Zealand) Ltd.**

8C Sylvia Park Road Mt.Wellington Auckland, New Zealand  
TEL: 09-573-7007 FAX: 09-573-7002

**TAIWAN SMC Pneumatics (Taiwan) Co.,Ltd.**

17, Lane 205, Nansan Rd., Sec.2, Luzhu-Hsiang, Taoyuan-Hsien, TAIWAN  
TEL: 03-322-3443 FAX: 03-322-3387

**HONG KONG SMC Pneumatics (Hong Kong) Ltd.**

29/F, Clifford Centre, 778-784 Cheung, Sha Wan Road, Lai Chi Kok, Kowloon, Hong Kong  
TEL: 2744-0121 FAX: 2785-1314

**SINGAPORE SMC Pneumatics (S.E.A.) Pte. Ltd.**

89 Tuas Avenue 1, Jurong Singapore 639520  
TEL: 6861-0888 FAX: 6861-1889

**PHILIPPINES SHOKETSU SMC Corporation**

Unit 201 Common Goal Tower, Madrigal Business Park, Ayala Alabang Muntinlupa, Philippines  
TEL: 02-8090565 FAX: 02-8090586

**MALAYSIA SMC Pneumatics (S.E.A.) Sdn. Bhd.**

Lot 36 Jalan Delima1/1, Subang Hi-Tech Industrial Park, Batu 3 40000 Shah Alam Selangor, Malaysia  
TEL: 03-56350590 FAX: 03-56350602

**SOUTH KOREA SMC Pneumatics Korea Co., Ltd.**

Woolim e-BIZ Center (Room 1008), 170-5, Guro-Dong, Guro-Gu, Seoul, 152-050, South Korea  
TEL: 02-3219-0700 FAX: 02-3219-0702

**CHINA SMC (China) Co., Ltd.**

7 Wan Yuan St. Beijing Economic & Technological Development Zone 100176, China  
TEL: 010-67882111 FAX: 010-67881837

**THAILAND SMC Thailand Ltd.**

134/6 Moo 5, Tiwanon Road, Bangkadi, Amphur Muang, Patumthani 12000, Thailand  
TEL: 02-963-7099 FAX: 02-501-2937

**INDIA SMC Pneumatics (India) Pvt. Ltd.**

D-107 to 112, Phase-2, Extension, Noida, Dist. Gautaim Budh Nagar, U.P. 201 305, India  
TEL: (0120)-4568730 FAX: 0120-4568933

**INDONESIA (Distributor) P.T. Riyadi Putera Makmur**

Jalan Hayam Wuruk Komplek Glodok Jaya No. 27-28 Jakarta 11180 Indonesia  
TEL: 021-625 5548 FAX: 021-625 5888

**PAKISTAN (Distributor) Jubilee Corporation**

First Floor Mercantile Centre, Newton Road Near Boulton Market P.O. Box 6165 Karachi 74000 Pakistan  
TEL: 021-243-9070/8449 FAX: 021-241-4589

**ISRAEL (Distributor) Baccara Automation Control**

Kvutza Geva 18915 Israel  
TEL: 04-653-5960 FAX: 04-653-1445

**SAUDI ARABIA (Distributor) Assaggaff Trading Est.**

P.O. Box 3385 Al-Amir Majed Street, Jeddah-21471, Saudi Arabia  
TEL: 02-6761574 FAX: 02-6708173